

**ACKNOWLEDGMENT OF
THE LAYTON COMPANIES
POCKET SAFETY HANDBOOK**

I have read the contents of the Layton Companies Safety Handbook.

I understand the contents of this handbook and that I am expected to abide by Layton Companies rules and regulations.

I UNDERSTAND THAT THIS
HANDBOOK DOES NOT CONTAIN ALL
STANDARDS OF CONDUCT AND
SAFETY RULES

PROJECT: _____

COMPANY: _____

SIGNATURE DATE

PRINT NAME

SIGNATURE OF PERSON DATE
WITNESSING AND/OR
REPRESENTING EMPLOYEE

TRAINING SESSION ON HAZARD COMMUNICATION

1. I know where the Material Safety Data Sheets (MSDS) for my work are kept.
2. I understand the safe work procedures and precautions to be taken when working with these products, including use of protective equipment and/or clothing.
3. I know where the emergency supplies are kept.
4. I know where the emergency phone numbers and Hazard Communication Information is posted.
5. I am aware that I may review copies of the Hazardous Chemical List, the Company's written program, and the MSDS.

SIGNATURE

DATE

PRINT NAME

SIGNATURE OF PERSON
WITNESSING AND/OR
REPRESENTING EMPLOYEE

DATE

Revised 3/2008

Layton

CONSTRUCTING WITH INTEGRITY



Since our modest beginning in 1953, The Layton Companies has been deeply concerned about safety and the general welfare of our employees. "Safety is No Accident" has been a value of our company for decades.

To again focus the attention of everyone who is a part of The Layton Companies, we have adopted a Risk Management program for all employees and subcontractors. It is our sincere objective to eliminate all occupational accidents and incidents on our projects.

To compromise this absolute objective with a tolerance of any degree is socially irresponsible. This formalized plan becomes a part of *The Layton Way* and the standard by which each one of us should be judged. We expect everyone involved with us to adopt these standards as their own.

David S. Layton
President

THE LAYTON COMPANIES BELIEVE IN CREATING AN INJURY-FREE ENVIRONMENT

What is an Injury-Free Environment?

NO Injuries!

Each person leaves each day in the same condition in which he or she arrived.

Characteristics of an Injury-Free Environment:

- We believe all injuries are preventable.
- We do not accept injuries as part of doing business.
- We are dedicated to the continuous improvement of our safety performance.

Three Key Elements of an Injury-Free Environment:

- Supportive leadership
- Personal commitment to safety
- Free and open lines of communication

What's Wrong with a Few Injuries?

- Just a few injuries could mean you or the person next to you will get hurt. Is that acceptable?

NO!

How Is It Possible to Work Injury-Free?

- Eliminating all injuries requires a ***Performance Breakthrough*** in safety, which includes:
 - A different method of preventing injuries;
 - Commitment of 100% of the organization.
 - It must come from a shift in the way we think of safety.

What Are the Root Causes of Occupational Injuries?

- National Safety Council – 96% of all injuries are caused by human factors or error.

In order to achieve an Injury-Free Environment, each of us must consider whether our acts are safe or unsafe.

How Do Our Personal *Values* and *Priorities* Affect Our Attitudes and Behavior Towards Safety?

What is a Value?

- Definitions:
 - “A principle or quality intrinsically desirable.”
 - “A deeply held belief.”

What is a Priority?

- Definitions:
 - “Superiority in rank, time or position.”
 - “Something meriting utmost attention.”
- Priorities CHANGE

Values Vs. Priorities

Value:

- Doesn't easily change
- Not readily influenced by others or circumstances
- Takes a life change to change a value

Priority:

- Can and will change frequently
- Can be easily influenced by others or circumstances
- Something that takes precedence over another.

In order to create an Injury-Free Environment,

SAFETY MUST BE A VALUE, NOT A PRIORITY!

What is compliance?

- To follow rules
- To yield to others

What is choice?

- Ability to select
- Option, alternative, preference

Understanding the Effect Compliance and Choice have on Safe Behavior

- Safe behavior and actions must be by choice to be truly effective.
- We must **choose** to be safe for ourselves, our families and our fellow workers, because we believe it is the right thing to do, **not** because someone told us to do it.

You can create an Injury-Free Environment by:

- Reporting all injuries or near miss incidents.
- Keeping your work area free of hazards.
- Pre-planning your work. Ask the “What if?” question.
- Doing extra planning when conditions change.

SAFETY PYRAMID

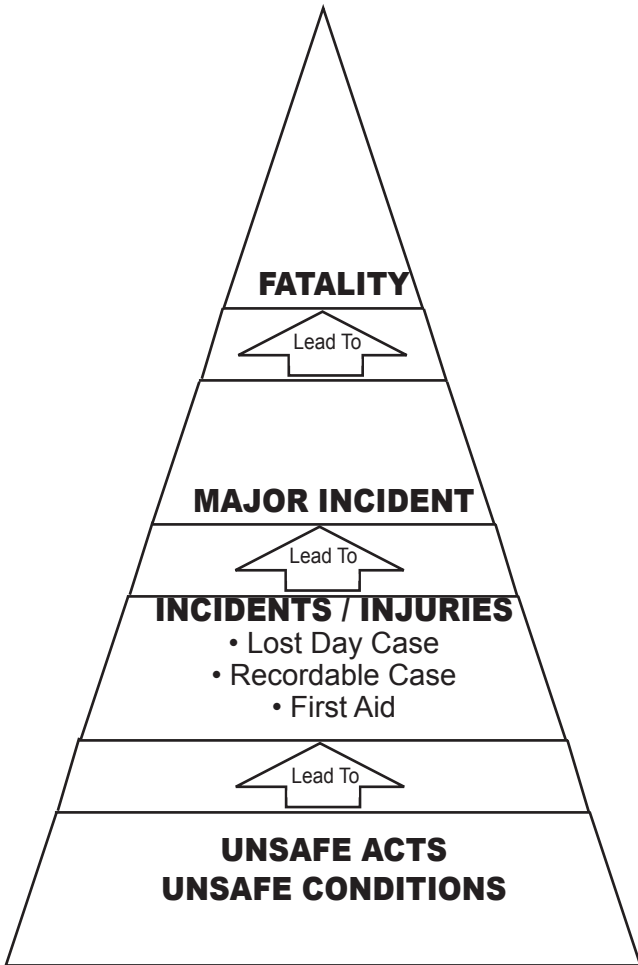

SUBCONTRACTOR STANDARD OF CONDUCT

Commonly accepted standards of conduct help maintain good relationships between subcontractors and Layton Employees. They promote responsibility and self-development. You can avoid misunderstandings, friction and disciplinary action by avoiding thoughtless or wrongful acts, such as the following:

THESE STANDARDS OF CONDUCT APPLY TO SUBCONTRACTORS ONLY PERFORMING WORK FOR LAYTON EMPLOYEES STANDARDS OF CONDUCT PLEASE SEE THE LAYTON COMPANIES EMPLOYEE HANDBOOK.

1. Failure to perform work, inefficient performance, incomplete or neglect work.
2. Willful refusal to perform work as directed (insubordination).
3. Anyone removing a lock other than their own, and/or ignoring or defeating any lock or tag shall be terminated.
4. Negligence in observing safety regulations, poor housekeeping, or failure to report on-the-job injuries or unsafe conditions.
5. Unexcused or excessive absence or tardiness.
6. Failure to call Superintendent or manager within one hour after the schedule start time on each day of absence.
7. Unwillingness or inability to work in harmony with others. Discourtesy, irritation, friction or conduct creating disharmony.
8. Horseplay, fighting, threatening, intimidating or coercing others on Company premises.
9. Bringing unauthorized weapons, firearms or explosives on Company premises.
10. Harassing or discriminating against another individual.
11. Failure to be prepared for work by wearing the appropriate construction clothing or bringing the necessary tools.
12. Violation of any other commonly accepted reasonable rule of responsible personal conduct.
13. Dishonesty or falsification in any form or degree.
14. Damage, loss or destruction of company, employee, or customer property due to willful or negligent acts.
15. Unauthorized possession, removal or use of property belonging to the company, customer or other Employees.
16. Being under the influence of or possession of alcoholic beverages, intoxicants or illegal drugs on Company premises.

17. Being under the influence of alcohol where the alcohol level is .02 or greater.
18. Safety violations that endanger themselves or other individuals.
19. Refusal to wear safety equipment.
20. Removing and/or crossing through red tape/red danger tape and/or working inside red tape or red danger tape without authorization.

Such behavior constitutes miss conduct can result in immediate removal from job site.

SAFETY ENFORCEMENT/DISCIPLINE

For minor offenses with minor consequences, written warnings a Subcontractor or individual will be expected to agree to improve behavior.

Removal from the project could result from major offenses, those with serious or costly consequences, or for repeated minor offenses for which the Subcontractor or individual shows a lack of responsible effort to correct deficiencies.

Layton will strive to preserve good working conditions for Subcontractors and encourages each to be responsible and conscientious. Violations will be kept on file.

WORKPLACE VIOLENCE

The safety and security of our subcontractors, customers, and the general public are of vital importance. Therefore, the Company has a policy of zero tolerance for violence. Subcontractors displaying or threatening any violence in the workplace are subject to immediate removal. No talk of violence or joking about violence will be tolerated. Unauthorized weapons are also prohibited on Company property and project sites.

We define violence to include physically harming another, shoving, pushing, harassment, intimidation, coercion, brandishing weapons, and threats or talk of violence.

It is everyone's business to prevent violence in the workplace. Subcontractors can help by reporting anything in the workplace that could indicate a co-worker is in trouble.

If a violent incident occurs on Company property, or job site, Subcontractors shall report it to Layton management immediately.

SUBCONTRACTOR'S RESPONSIBILITIES

All Subcontractors and their Employees are required to comply with The Layton Employee Handbook Safety and Drug Policies, Company Rules and all the owner competent person. OSHA Construction Standards along with all other state and local safety requirements while working on TLC sites or on Company premises.

PROCEDURE FOR SAFETY OF SUBCONTRACTORS

1. Each subcontractor must designate a safety representative.
2. In addition to the guidelines in the Layton Employee Handbook, the following guidelines are to be followed to protect all workers on TLC Projects.

a. Subcontractor is required to follow all guidelines found in the Layton Companies safety handbook.

b. Subcontractor shall at all times (a) provide its employees with safe appliances and equipment, and a safe place to work, (b) perform the work under this Contract in a safe manner with high regard for the safety of its employees and others, and (c) comply with all applicable health and Safety provisions and requirements of Contractor, local, state, and federal agencies including the Williams-Steiger Occupational Safety and Health Act; (d) indemnify and hold Contractor harmless from and against any costs, expenses (including attorneys' fees), losses, deficiencies, fines, or damages incurred related to or arising out of the failure of Subcontractor to comply with such regulations, acts and procedures. Failure to comply with all safety rules shall be cause for withholding further payment to subcontractor.

c. Subcontractor shall continuously clean up and remove from the site as directed by TLC. All rubbish and debris resulting from its work. Failure to clean-up such rubbish and debris shall be cause for withholding further payment to Subcontractor until such time as such clean-up has been accomplished to the satisfaction of Contractor. Subcontractor shall also clean-up to the satisfaction of Contractor all dirt, grease marks, etc., from walls, ceilings, floors, fixtures, etc., deposited or placed thereon as a result of the performance of this Contract. If Subcontractor refuses or fails to perform such cleaning as directed by Contractor, Contractor shall have the right to cause such cleaning to be performed by Contractor's employees or others, and Subcontractor will on demand pay to Contractor the cost to Contractor of such cleaning plus a reasonable percentage of such cost to cover supervision, insurance, overhead and other indirect costs and profit.

d. Subcontractor shall immediately inform Contractor of any notices, warnings, communications or asserted violations issued by government body related in any way to the Subcontractor's performance of this Contract and provide Contractor with a copy thereof. Subcontractor shall also immediately advise Contractor of any scheduled or unscheduled governmental inspections or site visits, and the results of such inspections and/or site visits related to the Subcontractor's work and provide Contractor with any copies thereof. Where advance notice is given of an inspection or site visit, Subcontractor shall immediately advise Contractor in advance of such inspection or visit. Where no advance notice is given, Subcontractor shall immediately advise Contractor of such inspection or site visit upon the arrival of the inspector or inspectors.

e. Contractor may deny access to the site by Subcontractor and its employees if, in Contractor's sole judgement, such action is justified on the basis of safety. Contractor may also suspend work at any time or terminate this Contract for cause in the event of Subcontractor's repeated failure to adhere to safety laws and regulations or Contractor's established on-site safety procedures. The foregoing reservation of such rights shall not give rise to a duty by Contractor to exercise such right for the benefit of any person, and shall not relieve Subcontractor of its obligations for safety hereunder.

f. Subcontractor shall maintain at the site of the work current records covering safety and health including training for employees working on the project, such records to be kept and maintained by subcontractor for the duration of this Contract. Subcontractor shall make such records available to Contractor for review at any time and from time to time upon Contractor's request for a period of at least three years after the completion of the project.

g. Subcontractor shall designate a competent person responsible for recognizing and correcting all safety hazards as defined in CFR 29 part 26.32(f) and throughout such standard. Competent person form must be filled out and competent person must be on site while work is being performed.

h. Subcontractor shall adhere to and enforce among its employees and subtiers all standards set forth in the Layton Companies Safety Handbook, including but not limited to:

The wearing of hardhats at all times outside of an office or enclosed cab.

The wearing of eye protection at all times outside of an office or enclosed cab. (Clear eye lens protection as a minimum for low light conditions.)

All subcontractors to have 100% fall protection when exposed to a 6' fall or greater when handrail protection is not provided, including steel erection.

The wearing of substantial leather above the ankle work boots, full-length pants and shirts with 4" minimum sleeve.

Not with standing the foregoing, adherence to such standards shall not relieve Subcontractor of its obligations for safety of the site of its work or the health of its employees.

****All new hires will receive verbal warning for safety violations during orientation.***

ALL VISITORS

(i.e. Owners, Architects, Engineers, Suppliers, etc.)

1. Check in with the Superintendent before proceeding onto the project.
2. Follow all safety rules and regulations; i.e. TLC Safety, the Occupational Safety and Health Construction Standards and all other state and local safety requirements.

TEMPORARY HELP

When using the Employees from a temporary employment service, the jobsite must train and document that he/she has been trained in the tasks he/she is to perform. Special attention will be given to the hazards the temporary Employee may encounter. The Employee must be trained in the procedures required to protect him/herself from those hazards specific to tasks assigned.

PERSONAL PROTECTIVE EQUIPMENT

All equipment will be inspected daily by user.

HARD HATS

1. All Contractors hard hats shall be worn correctly at all times, until the ceilings throughout the building are completely finished; all overhead hazards and hazards where there is the possibility of an injury to the head from impact from falling objects no longer exists. The only exception to wearing the hard hat correctly, are surveyors, structural steel erectors, equipment operators and welders and then only when welding!
2. Hard hats must be nonconductive. No cowboy hats will be allowed.
3. TLC employees should wear only Company-issued hard hats. These hard hats are Company property and should be returned upon termination of employment along with other Company-issued equipment.
4. TLC employees may display only Company-approved stickers on hard hats. Company-approved stickers include:
 - AGC logo sticker
 - AGC craft certification stickers
 - Safety sticker issued by the Company
 - Employee name tape
 - Years of service number
 - Project clearance stickers required for entrance on project sites (not project marketing stickers)
 - Craft Leadership Training Program stickers

EYE AND FACE PROTECTION

1. Eye injuries are one of the most frequent causes of injury in the construction industry. The following are the requirements for wearing eye protection. (Chop saws, torches, welders, etc.)
 - A. Safety glasses, which are approved by American National Standards Institute (ANSI) Z87, will be required at all times in the construction area. (Clear eye lens protection as a minimum for low light conditions.)
 - B. Employees, visitors and vendors are required to wear eye protective gear while in the construction area.
 - C. Face shields, burning goggles, welding helmets and chemical goggles will be provided and required on all activities presenting additional injuries. (Chop saws, torches, grinders, welding, etc.)
2. Mandatory eye protection is required on all individuals on all construction projects.
3. Visitors and vendors who are in construction areas will also be required

to wear eye protection. (See Appendix A for proper selection.)

4. Subcontractors will be required to wear eye protection at all times.

HAND PROTECTION

1. Gloves are issued to each TLC employee.
2. Gloves shall be worn where protection is needed against concrete, rough or sharp objects, hot materials, other chemicals, caustic or abrasive materials, during material handling. Subcontractors will provide hand protection when necessary per 1926. standards.

EAR PROTECTION

Ear protection devices shall be provided and worn whenever it is not feasible to reduce noise levels or duration of exposure.

PERMISSIBLE NOISE EXPOSURE (1)

| Duration per hrs./day | Sound Level dBA slow response | Duration hrs. | Sound Level dBA slow response |
|----------------------------------|--|--------------------------|--|
| 8 | 90 | 1-1/12 | 102 |
| 6 | 92 | 1 | 105 |
| 4 | 95 | 1/2 | 110 |
| 3 | 97 | 1/4 or less | 115 |
| 2 | 100 | | |

An action level of 5dB will be acted upon.

See Appendix J

RESPIRATORY PROTECTION

1. Air-Purifying Respirators shall be supplied and worn only when conditions warrant.
2. Atmosphere-Supplied Respirators shall be supplied when conditions warrant and after consultation with the Superintendent.
3. Half or full face respirators with HEPA filter cartridges must be used when soft cutting or grinding concrete. This requires the employee to have a medical evaluation and be trained and fit tested by the safety department.
4. Employees wearing a disposable respirator with two or more straps must be trained and have training documented and medical evaluation.

PERSONAL FALL PROTECTION SYSTEMS

1. A full body harness will be worn when working on an elevated platform that is 6 feet above the ground where guardrails are not provided.
2. 100% tie-off is required when working 6 feet or more above solid ground or above a temporary or permanent floor or platform when adequate fall protection is not provided. 100% fall protection requires two (2) lanyards with shock absorber.

PROPER DRESS

1. Full-length trousers shall be worn.
2. Shirts with a minimum 4" sleeve.
3. Leather over the ankle steel-toed boots with heavy sole. (Boots with a nonslip sole are recommended).
4. All Subcontractors will be required to wear leather over the ankle boot with a heavy sole.
5. Tank tops, shirts cut off at the midriff, cutoffs, sweat pants, moon boots, sandals, sneakers, jogging shoes, steel-toed tennis shoes, etc. are prohibited. (Visitors are required to maintain the same dress code.)

GENERAL SAFETY GUIDELINES

EMPLOYEES SHOULD UNDERSTAND THAT THIS IS NOT AN ALL INCLUSIVE LIST OF ALL STANDARDS OF CONDUCT AND SAFETY RULES.

ABRASIVE GRINDING

Abrasive wheel bench or stand grinders must have safety guards strong enough to withstand bursting wheels. Inspect and ring test abrasive wheels before mounting. Always leave wheel in working condition for next user. The tool rest must be 1/8" from grinding wheel.

AIR TOOLS

Secure pneumatic tools to hose in a positive manner with safety clips or retainers to prevent them from being accidentally disconnected or expelled.

COMPRESSED GAS CYLINDERS

1. Cylinder valves shall be closed when work is finished and when cylinders are empty or being moved.
2. Put valve protection caps in place before compressed gas cylinders are transported, moved, stored or when work is finished.
3. Cylinders of compressed gas shall be chained or otherwise secured in an upright position while in use or being stored.
4. Oxygen and acetylene regulators shall be in proper working order while in use.
5. Compressed gas hoses shall be free from leaks or poor connection and be neatly wound on hose hangers.
6. Oxygen and fuel gases must be
 - a. Stored in an upright position.
 - b. Have the Protective caps on tightly secured.
 - c. Be separated a minimum of 20 feet apart or by a wall constructed of non-combustible material 5 feet high with a minimum fire rating of one hour. Oxygen and Settling tanks stored in portable racks that are not used in 24 hours must be separated and stored properly.
7. Place a fire extinguisher approx. 25 ft. (no farther than 75 ft.) in the area.
8. Transport compressed gas cylinders secured, capped and in upright position.

CONCRETE SHORING

Form-work and shoring shall be designed by an engineer or a competent person and constructed to safely support all loads imposed during concrete placement. Drawings or plans of jack layout, form-work, shoring, working decks, and scaffolding systems shall be available at job-site.

CONFINED SPACE PROGRAM

A. DEFINITIONS

1. **Confined Space.** Any space that is large enough and so configured that a person can bodily enter, has limited or restricted means of entry or exit, and is not designed for continuous occupancy by people. Typical examples include tanks, drums, vessels, silos, hoppers, tank cars, tower skirts, boilers, furnaces, vats, large pipes, and others. Also included are spaces like trenches, pits, and cooling tower basins.
2. **Permit Required Confined Space.** Any confined space that has one or more of the following characteristics:
 - a. Contains or has a potential to contain a hazardous atmosphere.
 - b. Contains a material that has the potential for engulfment of a person.
 - c. Has an odd internal shape such as sloping sides or a conical floor.
 - d. Contains any other recognized serious safety or health hazard, such as high noise levels or heat.
3. **Entry.** Passing any part of the body past the plane of an opening of a confined space.
4. **Authorized Entrant.** A person who has been trained in The Layton Companies Confined Space Program, has signed the Confined Space Entry Permit, and will actually enter the confined space.
5. **Entry Supervisor.** The Layton Companies person who is responsible for determining acceptable entry conditions, handling the entry permit, overseeing the whole operation and has been trained in the Layton Companies Confined Space Program.
6. **Attendant.** A person who has been trained in The Layton Companies Confined Space Entry Program, has signed the Confined Space Entry Permit as attendant, and remains outside the confined space to monitor activity. (Also referred to as Manway Watch or Standby Person.)

B. RESPONSIBILITY

1. Management shall develop and monitor a Permit Required Confined Space Entry Program (PRCSE). They shall insure that the program is effective through annual assessment.
2. Supervision shall insure that all provisions of this Standard are strictly followed. They shall see that suitable equipment necessary to meet these provisions is provided. They shall see that required training is completed and documented before work involving PRCSE is begun.

3. The Field Safety Manager shall insure that all Layton Companies provided equipment for PRCSE is in good working condition and has a current calibration if required. They shall support supervision in training.
4. Each employee is responsible to follow all provisions of this procedure and additional client requirements as directed by their supervisor. They shall not enter any Confined Space if they have any doubt about its safety; nor if they have not been formally trained in PRCSE.

CRANES, MACHINERY, AND CONCRETE PUMPS

1. Operators of all heavy equipment (i.e. crane, forklift, backhoe, etc.) must be trained or certified.
2. All machinery shall be shut down with motor off prior to cleaning, fueling, lubricating or repairs.
3. Cranes, rigging and equipment shall be checked before each day's use by the operator. Any defects shall be corrected before use. An inspection log shall be kept on the machine, recording safety checks and proper fluid levels. (See Appendix E for good rigging practices.)
4. Rated load capacities, hand signals, and special hazard warnings shall be conspicuously posted on all equipment.
5. Accessible areas within swing radius of all types of cranes used by TLC will be barricaded to prevent Employees from being struck or crushed.
6. Only the operator will be allowed on the crane within the barricaded areas, except when there is a need to talk to the crane operator.
7. The only time an individual will be allowed to talk to the operator is when he/ she is able to do so safely.
8. No one will be allowed at any time to eat, sit, stand or ride on any equipment, except the operator.
9. Except where electrical distribution and transmission lines have been deenergized, no part of the crane or its load, concrete pump or its hose, or any other piece of equipment shall be operated within 10 feet of a line rated below 50kV or twice the length of the line insulator when over 50kV. For lines rated over 50 kV, the minimum distance between the equipment and the load must be 10 feet plus 4 inches for each additional 1 kV.
10. Only one signal person using proper hand signals shall direct equipment.
11. Crane operators shall not swing loads above areas where others are working, and shall stop use of crane during high winds or lightning storms.
12. Concrete pump truck procedure.

13. Riding the hook, ball, load or equipment buckets is absolutely prohibited.
14. Guidelines For Working Around Power Lines. The following policy is to be implemented when using equipment such as cranes or dump trucks, in and around power lines.
 - A. Notify the power company of your intentions and ask if additional precautions need to be taken.
 - B. Notify the safety department in a timely manner.
 - C. A meeting will be set up between the superintendent and a representative of the safety department in order to put a plan together that will adequately protect personnel and equipment working in the specific area. The plan will also include what to do in case of an emergency.
 - D. Once the plan is adopted and approved, everyone working in that area will be notified with the meeting documented.
 - E. This plan will be on file and made available upon request.
 - F. When working around power lines, extreme caution must be used. For power lines over 50kV, a minimum clearance between the lines and any part of the equipment, i.e. cranes, dump truck, etc. is 10 feet plus 0.4 inches for every 1kV over 50kV.
 - G. A person shall be designated to observe clearance of equipment and shall be able, in a timely manner, to warn the operators when it is difficult for the operator to maintain the required clearances.
15. If an employee who operates a piece of equipment is involved in an accident, he/she will be retested and evaluated to see if he/she is still competent enough to keep their certification.
16. If any part of this policy is violated, disciplinary action will be taken.
17. See Appendix C & D, for Crane & Pump truck hand signals.

DISASTER PLANNING

• Earthquake • Flood Control • High Winds • First Aid • Firefighting

1. Emergency plans for 24 hours a day, seven days a week.
2. Map out gathering areas for Employee count.
3. Notification sequence and communication to Employees.
4. Company contacts for communication with media.
5. Utility main shutdown.
6. Site Security.
7. Site shutdown procedures.
8. Outside help (Police, Fire Dept., Utility Co., etc.)

MONTHLY INSPECTION PROCEDURES

Items to be inspected monthly by a competent person:

- A. Personal fall protection equipment.
- B. Electrical cords and power tools.
- C. Ladders
- D. Fire extinguishers
- E. Rigging

General

1. The name of the competent person will be documented and published to all employees; any employee who falsifies a monthly inspection result will be disciplined up to and including termination.
2. The monthly color code will be mentioned at the weekly tool box safety meetings, including the individual employee's responsible to perform daily visual inspections of their equipment.

SAFETY COLOR CODE OF THE MONTH

January and July

Yellow

February and August

White

March and September

Brown

April and October

Green

May and November

Red

June and December

Blue

FALL PROTECTION

1. When working on or around all unprotected openings, such as openings on walls and floors that are 12 or more inches in their least dimension, and are six feet or more of fall to include ramps, runways, steep and low pitched roofs, and other walkways that may apply, employees must be protected by the use of a guardrail system, safety nets, or personal fall arrest system.
2. All crafts required to have 100% tie-off or the use of safety nets or guardrail system must be used when working 6 feet or more above solid surface for all crafts.
3. Leading edge – A leading edge is an edge of a floor, roof, framework, floors or other working surfaces such as a (deck) that is unprotected on the sides and edge when it is not actively under construction. When an individual is constructing a leading edge they must be protected from falling by the use of a guardrail system, safety net or a personal fall arrest system unless it can be demonstrated by other means that can be used safely. If other means are used the project must have a site specific written training program.
4. Wall Openings - Each Employee working on, at, above, or near wall openings (including those with chutes attached) where the outside bottom edge of the wall opening is 6 feet (1.8m) or more above lower levels and the inside bottom edge of the wall opening is less than 39 inches (1.0m) above the walking/working surface, shall be protected from falling by the use of a guardrail system, a safety net system, or a personal fall arrest system.
5. Excavations - Guardrail systems such as fences or barricades are to be used when the excavation cannot be seen due to plant growth or other visual barriers or when excavation is in remote areas such as wells, pits or shafts and is 6 feet or more in depth.
6. Warning Lines - When a warning line is used on a roof, it must be erected around all sides of the roof area not less than 6 feet back from the edge. The lines may consist of ropes, wires or chains with tensile strength of 500 pounds after being attached to a stanchion. It must be supported so that the sag or lowest point is not less than 34 inches. If the highest is 39 inches, it must be flagged at 6 foot intervals with high visibility. The stanchion must be able to resist tipping over when a force of 16 pounds is applied to it. No Employee will be allowed beyond the warning line unless he/she has work to do in that area. If he/she does have work in that area, the Employee must use a personal fall arrest system, safety monitor, or both.
7. Controlled Access Zones - A controlled access zone is an area clearly marked where leading edge work will take place without the use of a guardrail, safety net, or personal fall arrest system such as overhead

brick layering or related work.

- A. When used to control access to areas where a leading edge exists and/or other operations are taking place the controlled access zone shall be defined by a control line, or by any other means that restricts access.
 - B. When control lines are used, they shall be erected not less than 6 feet or more than 60 feet, or half the length of the member being erected, whichever is less, from the leading edge.
 - C. The control line shall extend along the entire length of the unprotected or leading edge and shall be approximately parallel to the unprotected or leading edge.
 - D. The control line shall be connected on each side to a guardrail system or wall.
 - E. Control lines shall consist of ropes, wires, tapes, or equivalent materials, and supporting stanchions.
 - F. Each line must be visibly marked at 6 foot intervals including perimeter cables.
 - G. Each line must have a minimum breaking strength of 500 pounds.
8. Precast - Employees engaged in the erection of precast, which include but not limited to: wall panels, columns, beams, floor and roof “tees” and related tasks such as grouting and are exposed to six feet or more fall will be protected by a standard guardrail system, safety nets or a personal fall arrest system.
9. Installation of Metal Decking - Metal decking shall be laid tightly and immediately secured upon placement to prevent accidental movement or displacement.
10. Runways, ramps and other walkways will be guarded by a standard railing on all open sides 6 feet or more above floor on ground level. Fall protection is required.
11. Stairs having four or more risers will be equipped with a standard railing.

ELECTRICAL

On many OSHA inspections the majority of violations found are electrical. Following are some of the most common electrical violations found.

- 1. Extension cords are not to be used as a substitute for permanent wiring. Do not run them through doors without protection.
- 2. Do not allow cords to be run over by equipment unless properly protected against damage.
- 3. Do not use household 4 way boxes unless they are waterproof.
- 4. Make certain they are wired properly.

5. Check for reverse polarity.
6. All outlets must be GFCI protected except for temporary lighting during all phases of construction.
7. Splicing/Repairing electrical cords. Do not use electrical tape. Use a vulcanizing tape or a shrink tube.
8. Take all damaged cords out of service when plug ends have pulled away from the outer insulation, or they have cuts or tears in the outer insulation where the inner wires are exposed, or ground pins are missing or broken.
9. Inspect cords monthly and before using. Use monthly color code system to document monthly inspection.
10. Repairs should be done under the direction of an qualified personnel.

GENERAL PRECAUTIONS:

1. Only a qualified person trained to perform electrical work will perform installation, maintenance, or repairs on electrical wiring, tools, equipment, and machinery.
2. Employees must consider all electrical conductors as energized.
3. Personnel authorized to perform work on electrical circuits shall be trained in First Aid and CPR.
4. Suitable personal protective equipment including rubber gloves, mats, and blankets to provide insulation from other elements which are energized or grounded shall be used.
5. Personnel shall not wear rings, watches, or similar metallic objects while working on energized electrical equipment.
6. Do not render electrical interlocks inoperative by removal, modification, or destruction.
7. Blown fuses shall be replaced with the proper type and rated fuses only.
8. Non-conductive ladders when working on or near electrical equipment or conductors shall be used. Metal ladders shall not be used.
9. Defective electrical equipment or extension cords shall not be used. Defective equipment shall be tagged out of service and reported to supervision
10. Always determine if buried electrical cables, or other utilities are present before excavating, internal resources, one call, or utility company, and/or a combination of all shall be used.
11. When downed electrical lines are discovered, barricade off the area and notify local authorities and the local power utility, do not enter an exposed zone.
12. All low voltage electrical equipment shall be equipped with ground fault

circuit interrupters to minimize shock hazard.

13. Electrical equipment that contains capacitors shall be identified. This equipment shall be properly grounded prior to maintenance to minimize shock hazard.
14. Lightning can be a deadly electrical hazard. Never work out in the open or around metal objects or tall structures during electrical storms. All equipment equipped with extended booms such as cranes, derricks, or excavators shall be lowered during electrical storms.
15. Temporary lighting shall be equipped with guards to prevent accidental contact with the bulb, and secured with non conductive material.
16. Generators must be properly grounded, mats, rebar, or structures are not considered to be an appropriate ground.

IDENTIFICATION OF POWER TOOLS, TEMPORARY POWER CABLES AND EXTENSION CORDS

1. Place some types of contractor identification, i.e. tags, on all power tools, temporary power cables, and extension cords.
2. Notify the Superintendent or Foreman of any power tools, temporary power cables and extension cords that are not in compliance with the National Electrical Code and OSHA Construction Standards so they can be replaced or repaired.
3. If any power tool, temporary power cable or extension cord not in compliance can be identified as to which Contractor it belongs, the contractor will be notified of the violation.
4. If the Contractor fails to correct the violation, a representative of TLC will issue a warning.
5. If, after issuing the warning, the Contractor does not comply, the power tool, temporary power cable or extension cord must be removed from service by a TLC representative.

EXCAVATION AND TRENCHES

1. Walls of trenches and excavations five (5) feet more in depth in which Employees are exposed to danger from moving ground or cave-in shall be guarded by shoring or sloping.
2. Trenches four (4) feet deep or more require adequate means of exit such as a ladder located so as to require no more than 25 feet of lateral travel.
3. Excavations and trenches which are five (5) feet or more in depth and less than twenty (20) feet in depth that do not meet the requirements for type A, B, or C soil the protective systems must be designed by a Registered Professional Engineer (RPE).
4. Excavations and trenches which are twenty (20) feet or more in depth the

- employed protective system must be designed by a R.P.E.
- When an excavation or trench requires a R.P.E. to design them, the R.P.E. must be registered in the state for which the excavation and trenching is taking place.
 - The design criteria by R.P.E. for protective systems for the excavation and trenches must be kept at the job-site and contain the following information:
 - Be in written form to include the size, type and configuration of materials to be used in the protective system and identify the R.P.E. appointing the design. (See CFR 1926.650 & 651 for further information.)
 - See Appendix M.

FIRE PROTECTION

- Fire fighting equipment shall be conspicuously located, readily accessible (especially when welding or cutting with a torch), periodically inspected and maintained in operating condition. Report any inoperative or missing equipment to your Superintendent. See inspection procedure.
- When welding, cutting or burning, remove the following:
 - All combustibles 35 ft. radius
 - All flammables 50 ft. radius
 - All explosives 100 ft. radius
 - When it is impossible to remove the above, a fire watch is required
- Each office and tool trailer shall have at least one 10 lb. ABC fire extinguisher on hand.
- For proper selection of fire extinguishers see Appendix F.

FLAMMABLE & COMBUSTIBLE LIQUIDS

- Only U.L. or equivalent approved metal containers and portable tanks will be used for storage and handling of flammable and combustible liquids.
- No more than 25 gallons of flammable or combustible liquids may be stored in a room outside of an approved storage cabinet.
- Tank storage shall not be located under power lines.
- Signs with "NO SMOKING WITHIN 50 FT." shall be posted on or near the flammable/combustible storage area.
- A fire extinguisher with a 20 lb. ABC rating shall be available within 75 feet but no closer than 25 feet during the transfer of flammable liquids.

HAZARD COMMUNICATION

- The Hazard Communication Standard required Employers to provide information on all hazardous substances that may be present in the work place. Subcontractors or Vendors bringing hazardous materials on TLC premises or job-sites are required to have available Material

Safety Data Sheets (MSDS) for that material. The manufacturer of that material is required to provide MSDS with hazardous substances. The Superintendent shall provide Subcontractors and Employees on the project with MSDS at their request.

2. Compile a list of all toxic materials on the project and check the TLC Hazard Communication Booklet for Material Safety Data Sheet (MSDS) for each of the hazardous materials. If there are substances not covered in the TLC Hazardous Communication Book, the Superintendent will notify the Office.
3. Label chemicals properly and keep all containers accurately labeled, identifying current contents.
4. Avoid incompatible storage or storage of chemicals above eye level.
5. In the project Safety Meeting review hazardous materials that are being used on the project and train Employees and Subcontractors in:
 - a. Provisions of the Hazard Communication Standard.
 - b. How to detect a chemical exposure.
 - c. Physical and health hazards of chemicals in use.
 - d. Use and availability of Material Safety Data Sheets.
 - e. Safe work practices and personal protective equipment.
6. Detailed records of Employee training shall be maintained to prove that the training requirements have been met.
7. Have upon request:
 - a. Copies of the TLC's Written Hazard Communication Program.
 - b. Copies of the OSHA Hazard Communication Standard.
 - c. A list of hazardous chemicals on your job-site.
 - d. Copies of Material Safety Data Sheets for any hazardous material to which your job-site is exposed.
8. Refer to the "Hazard Communication Program" that can be found in the TLC Hazard Communication Book.
9. For instruction on how to read Material Safety Data Sheets and labels on containers, see Appendix G.

ORDERLINESS / HOUSEKEEPING

1. Good housekeeping is an indication of an efficiently run job. Keep all projects clean and free of debris and rubbish. Trash piles shall be removed at regular intervals. Containers shall be provided for collection of all refuse.
2. Scrap lumber, pipe, fittings, hoses, weld cables, power cords and all other materials shall be kept clear from work areas, hallways and stairs.
3. Remove protruding nails or screws.
4. Dispose of lunch and break garbage in trash containers.
5. Store materials and supplies segregated as to size and types. These materials are not to intrude into walkways or traffic ways.

6. Throwing materials from elevated platform is not allowed unless barricaded signal person is directing.
- 6a. A trash chute must be used when throwing trash or other material over the side of the building when the height is 20 or more feet.
7. Eating allowed in designated areas only as directed by the Superintendent.

LADDERS

1. An employee shall not use a ladder that has been broken, loose or cracked rungs, side rails or braces. If such a condition is noted, remove from service and notify the Superintendent so it can be repaired or replaced, inspection before each use and monthly. See inspection procedure.
2. Ladders shall be well secured to prevent movement and sufficient length to extend not less than 36 inches above any platform or landing which they serve.
3. Employees shall not work on the top two steps of a step ladder and/or above the third rung of an extension ladder.
4. When ascending or descending ladders, Employees shall have hands free, grip the sides or rungs with both hands, and face the ladder.
5. Ladders used for access shall be placed at a 4 to 1 ratio. For every 4 ft. of vertical height from the structure the ladder is to be placed 1 ft. way.
Example: If the structure is 12 ft. high the ladder would be 3 ft. away from the base of the structure.
6. Job-made ladders shall be constructed so that cleats shall be inset into side rails or filler blocks used. Cleats shall be uniformly spaced, 12 inches, top-to-top.
7. For common sense practice. See Appendix H.

LIGHTING

1. The intensity of lights shall be 3 foot-candles in general construction areas and 5 foot-candles or greater on any walkway, ladder, stairway or working level while work is in progress.
2. Temporary lights shall be equipped with guards to prevent accidental contact with the bulb, except when the light bulb is deeply recessed and protected by the lamp holder.

LOCK OUT/TAG OUT

CONTROL OF HAZARDOUS ENERGY SOURCES

Lockout Permits will serve as records of equipment and personnel that have been involved in the lockout/tagout of hazardous energy sources. The original signed permits shall be returned to the Superintendent or Foreman. These permits will be returned to the Safety Coordinator, and kept as a

record for three years.

ENFORCEMENT:

The Superintendent shall enforce the provisions of this program. Anyone removing a lock other than their own, and/or ignoring or defeating any lock or tag shall be terminated.

BASIC RULES:

1. All equipment, piping, electrical circuits, sources of stored energy (e.g., fly wheels, parts that can be activated by wind, or gravity, suspended machine parts, etc.), pneumatic and pressurized systems shall be locked out or isolated to protect against accidental or inadvertent operation when such operation could cause injury to personnel.
2. The authorized person in charge of the job requiring lockout/tagout or pipeline isolation shall make a survey to locate and identify all isolating devices to be certain which switches, valves, or other energy-isolating devices apply to the equipment or piping segment to be locked out or isolated. **Note:** more than one energy source (electrical, hydraulic, or others) may be involved.
3. The distribution, storage, and issuance of locks, lockout devices, isolation devices, and tags shall be the responsibility of the Superintendent or a designated alternate (may be a Foreman, multiple keyed locks are not acceptable for a lockout).
4. No employee shall remove another employee's lock.
5. Lockout and tagout devices shall be standardized on each project and within each operating area in at least one of the following criteria:
 - Color
 - Shape
 - Size
6. In the case of tagout devices, print and format shall be standardized. Lockout devices and tagout devices shall include the following:
 - The identity of the employee applying the device(s);
 - The date;
 - Reason for the lockout/tagout; and
 - Warning instructions such as: "DANGER, DO NOT OPERATE", "DO NOT START", or other similar language.

MEDICAL SERVICES AND FIRST AID

1. There will be a person trained to render first aid on all projects.
2. First aid supplies shall be readily available and stored in either or both the tool and office trailer(s).
3. All emergency telephone numbers shall be conspicuously posted near the phone (i.e. 911, ambulance, hospital, doctor, fire and police departments, paramedics.).

4. See Appendix K and O.
5. For a list of TLC's medical Treatment Providers, see Appendix O.

EARLY RETURN TO WORK PROGRAM

When an Employee has a work related injury or illness the Employee will stay on the project where the injury occurred until he/she has been released to full duty. If the project can not accommodate the injured person, the SBU leader will assign a project and task for this individual. The employee is to understand this temporary position is not permanent. Once he/she has been released to full duty, the employee will be returned to their regular duties as they are assigned.

MOTOR VEHICLES

1. Safety Belts shall be properly fastened by employees while driving or riding in Company vehicles. In cases of repeated or flagrant violations of this policy, appropriate disciplinary action shall be required - including revoking the use of Company vehicles.
2. Before an employee will be allowed to drive a company vehicle, Layton Construction will check his/her driving record to make certain there are no problems which would cause TLC to put themselves and others in harm's way.
3. Smoking is not allowed in TLC Vehicles.
4. Riding in the back of a pickup truck is prohibited.

POWDER-ACTUATED TOOLS

1. Only trained Employees shall be allowed to operate powder-actuated tools.
2. Certification is to be updated annually.
3. Any defects discovered during use shall be immediately corrected or the tool shall be removed from service until properly repaired.
4. 1926.302 tools shall not be loaded until just prior to intended firing time. Neither loaded nor empty tools are to be pointed at any employees. Hands shall be kept clear of the open barrel end. Loaded tools shall not be left unattended.

POWER-OPERATED AND HAND TOOLS

1. No power tool shall be operated without a properly adjusted guard in place.
2. Hand tools shall be used only for the purpose for which they were designed and shall be kept in good repair.

3. Pneumatic power tools shall be secured to the hose by some positive means to prevent the tool from becoming accidentally disconnected.
4. Any tool found not in proper working order, or that develops a defect during use, shall be removed from service until properly repaired. See inspection procedure.

PROTECTION FOR THE GENERAL PUBLIC

1. Protect the general public from injury or accident by providing warning and protective devices (i.e. signs, flags, lights, barricades), and keeping pedestrian walkways free from obstacles, obstructions and debris.
2. Where vehicular traffic needs to be rerouted, post a flag person or have required signing.
3. Keep spectators (especially children) away from the job-site. Always be courteous but firm in dealing with the public.
4. In the event of an accident involving the public that results in bodily injury or property damage, the Superintendent shall make a detailed written report on the day of the accident and subject it to the Project Manager.
5. The Superintendent, in addition to filing a report, should call the Safety Director/Risk Manager so a follow-up investigation can be made.

PERSONAL CELL PHONES, RADIOS, TAPES OR CD PLAYERS

The use of personal cell phones, & audio equipment during working hours is prohibited (with exception of breaks and lunch)

SCAFFOLDS

1. Scaffolds shall be capable of supporting at least (4) times the maximum intended load and erected on sound, rigid footings, capable of carrying the maximum load without setting or displacement. The standard guardrail is the top-rail minimum 38" and not more than 45" high. The mid-rail is 1/2 the distance. See Appendix L (Page 90).
2. Fall protection shall be provided when the top-rail is 38" or less.
3. Cross braces may be used as part of the guardrail system when the top-rail or mid-rail meet the following requirements.
 - a. Top-rail when the distance where the braces cross is between 38 and 48 inches.
 - b. Mid-rail when the vertical distance where the braces cross is between 20 and 30 inches.
4. Standard guardrail must be used on all open sides when the height of the scaffold is 6 feet or greater.
5. Scaffold shall be fully planked with a maximum space between planks not greater than 1 inch.

6. Planks that overlap each other must overlap at least 12 inches. If they do not overlap over a support which is attached to the frame, they must be nailed down or secured by some other means.
7. Scaffold planks shall extend at least 6 inches and no more than 12 inches beyond the last support when the span is 8 feet. If the span is 10 feet the distance may extend no more than 18 inches.
8. All walking surfaces must be at least 18 inches wide.
9. A ladder must be attached when the distance between the rungs is greater than 16 3/4 inches or when the width is less than 12 or greater than 16 inches.
10. Maximum distance from the wall or structure following the manufacturers directions or at a ratio of 4:1 then at intervals not to exceed 30 feet horizontally and 26 feet vertically when the scaffolds are greater than 3 feet wide. Scaffolds less than 3 feet wide the intervals are 20 feet vertically and 30 feet horizontally.
11. Cross braces cannot be used as an access or egress.
12. All training must be documented and made available upon request.
13. OSHA requires everyone on your project to be properly trained. This includes employees of subcontractors. The Superintendent should keep a list of all the employees who have been trained before they can work on, erect, or dismantle scaffold.
14. Scaffolding and accessories with defective parts shall be immediately replaced or repaired.
15. Employees using or erecting and dismantling must be trained in proper use and hazards associated with these activities.

TRAINING REQUIREMENTS

DEFINITIONS

Competent Person: One who is capable of identifying existing and predictable hazards in the surrounding or working conditions which are unsanitary, hazardous, or dangerous to employees, and whose authorization you take prompt corrective measures to eliminate them.

Qualified Person: One who, by possession of a recognized degree, certificate, or professional standing, or who by extensive knowledge, training and experience, has successfully demonstrated his/her ability to solve or resolve problems related to the subject matter, the work, or the project.

EMPLOYEE(S) PERFORMING WORK ON SCAFFOLDS

1. Trained by a person qualified in the subject matter to recognize the hazards associated with the type of scaffolding being used and to understand the procedures to control or minimize those hazards. The training will include the following:
 - a. Electrical, fall, and falling object hazards in the work area.
 - b. Hazards associated with disassembling the fall protection and falling object protective systems.

- c. The proper use of scaffold and the proper handling of materials on the scaffolds.
- d. The maximum intended load and load carrying capacities of the scaffolds used.
- e. Any other pertinent requirements for working safely on the scaffold.

EMPLOYEE(S) INVOLVED IN

1. Erecting, disassembling, moving, operating, repairing, maintaining, or inspecting the scaffold.
2. Training by a competent person to recognize any hazards associated with the work.
 - a. The nature of the scaffold hazard.
 - b. The correct procedures for erecting, disassembling, moving, operating, repairing, inspecting, and maintaining the scaffold.
 - c. The design criteria, maximum intended load and use.

RETRAINING

Retraining is to be done when the following conditions exist:

1. Have reason to believe the employee shows inadequacies in work activity while on the scaffold, erecting and dismantling.
2. Where changes at the work site present hazards in which the employee has not been trained.
3. Changes in the type of scaffold, fall protective systems being used.
4. For additional information see CFR 29. 1926, subpart L.

STORAGE

1. All materials shall be secured to prevent sliding, falling or collapse.
2. Aisles, passageways and exits shall be kept clear.
3. The project Superintendent will approve of an area prior to stocking materials.

AERIAL LIFTS

An aerial lift is any vehicle or device that has:

1. An extendible boom.
2. Aerial ladders.
3. Articulating boom platforms.

All of the above require personnel to be tied off (scissor lift's optional) while working on or inside these platforms. Tie-off is not mandatory in scissor lifts, but must be available.

PROTECTING PROTRUDING REINFORCED STEEL AND OTHER IMPALEMENTS

1. All protruding reinforced steel will be protected both vertically and horizontally where a person can fall on to or into it.
2. Fall protection will be provided when working above impalement.
3. See Appendix I for instructions on how to properly protect.

TEMPORARY HEATING

1. Oil-fed heaters shall be shut down and allowed to cool before being moved or refueled to reduce the hazard of flashing vapors in the stack.
2. Heaters shall be placed so they will not interfere with traffic patterns on the job.
3. Attendants shall be aware of the possibility of carbon monoxide poisoning. Adequate provision for monitoring the air quality shall be made. Report any buildup of harmful vapors to Superintendent and evacuate the area.
4. For further instructions on temporary heating and proper use and care of L.P. gas containers refer to the TLC Safety Manual.

THEFT AND VANDALISM

1. Safeguard the job-site from theft and vandalism. TLC and its Subcontractors, on open job-sites, are easy prey to vandals. A plan shall be implemented to protect the job-site from:
 - Theft
 - Vandalism
 - Fire by arson or accident
 - Attractive nuisance resulting in injury or death.
2. The following list shall be implemented as a minimum for a site security system:
 - Careful scheduling of materials. (Keep excess materials off job-site.)
 - Organized receiving site that confines materials in a specific area.
 - Entire area enclosed by a security fence.
 - Area shall be lighted at night and visible from adjacent streets.
 - Small high value items shall be stored in locked enclosures.
 - A separate parking area for Employees' vehicles will help control the disappearance of tools and materials.

TOILETS

1. One toilet facility shall be provided for every 20 or fewer Employees and be cleaned and serviced weekly.
2. Creating or contributing to unsanitary conditions or failing to use the toilet facilities provided shall be cause for disciplinary action or expulsion from the project.

VENTILATION

1. When working in an enclosed area, the air quality shall be monitored for dangerous levels of gases, dusts or fumes (i.e. carbon monoxide, nitrogen dioxide or harmful dusts).
2. No quantities of toxic or noxious dusts, fumes, vapors or gases shall exceed the threshold limit values adopted by the American Conference of Governmental Industrial Hygienists.
3. An air quality control test may be performed by the Industrial Commission at no charge.
4. Tests should be conducted periodically by a trained competent person and all test data recorded in the Superintendent's daily log.
5. Refer to the Respiratory Protection Program in the TLC Safety Manual.

LASER

The following are some common sense rules for using levels, lasers and transits.

1. Set up in low traffic areas and near barriers if possible.
2. Avoid the path of extension cords, welding cables, and air hoses.
3. On a large job use a permanent location if possible.
4. Set up over dirt or grass if possible.
5. Set laser 12 to 18 inches lower than an optical level. (You are not looking through it.)
6. Keep legs on tripod in a wide stance and hobble the legs if set on concrete.
7. Tie fluorescent flagging to tripod legs.
8. Keep level and laser cases closed while using the instrument to keep dirt and moisture out. Protect levels, lasers, transits, and accessories from moisture.
9. Never carry a level, laser, or transit over your shoulder while still attached to the tripod.
10. Set up instruments away from compaction equipment.
11. Put instruments away when not in use and store in a secure location.
12. Where applicable, have warning signs clearly displayed.
13. Have workers properly trained and OSHA training cards in their possession.
14. Insist on proper training for use of laser.
15. Always carry training verification card.

16. Be sure to post "Caution-Laser Light" placard on the job site.
17. Shut off laser when not in use.
18. Do not direct laser at persons or vehicles.
19. Do not look directly into beam.
20. Always use target supplied with system.

GUIDELINES FOR USING NAIL GUNS

All operators must be trained and certified.

1. Always wear eye, ear and head protection.
2. Never use bottled gases.
3. Do not exceed 120 psi
4. Never relocate with finger on trigger.
5. Never point nailer toward yourself or anyone else.
6. Store nailer properly.
7. Keep work area clean.
8. Never use in presence of flammable liquids or gases.
9. Keep visitors away.
10. Dress properly.
11. Never use a non-relieving coupler on nailer.
12. **Never use if safety or push lever is missing.**
13. Check push lever before use.
14. Keep all screws and covers tightly in place.
15. Do not load fasteners with trigger or push lever depressed.
16. Keep hands and feet away from firing head during use.
17. Place nailer properly on workplace.
18. Take care of double fire due to recoil.
19. Do not drive fasteners into thin boards or near corners and edges of workplaces.
20. Never drive fasteners from both sides of a wall at the same time.
21. Check for live wires.
22. Never carry nailer by hose.
23. Do not overreach.
24. Never use nailer which is defective or operates abnormally.

25. Do not disconnect air hose from nailer with finger on trigger.
26. Disconnect air hose from nailer when
 - a. doing maintenance and inspection;
 - b. cleaning a jam;
 - c. it is not in use;
 - d. leaving work area;
 - e. moving it to another location; and
 - f. handing it to another person.
27. Stay alert.
28. Handle and maintain nailer per manufacturers guidelines.
29. Never use nailer for applications other than those specified in this manual.
30. Insure all personnel are removed or barricaded out of adjacent areas where nail could penetrate through material striking personnel.

CRIME PREVENTION

1. Label all tools and equipment with a marking system to prove ownership. Recommend paint and number system.
2. Take pictures to help identify and recover.
3. Hold tailgate prevention meetings.
4. Invite Police to visit job site.
5. Community relations.
6. Send out Neighborhood Security Watch Bulletins explaining what you're doing and you would appreciate it if you help watch the project. AMCC Construction does this and according to them, it has worked.
7. Pre-Construction Meetings: Invite Police, Schoolboard, Civic Association, Chamber of Commerce.
8. Establish a reward system to include a 24 hour hot line and posters.
9. Install a six (6) foot fence with 'NO TRESPASSING' signs, crime prevention warning signs and reward signs.
10. Protective iron on all windows within 14 feet of the ground.
11. Teach employees to challenge strangers.
12. Escort non-employees to personnel.
13. Check delivery vehicles in and out of project.
14. Lock all power sources at the end of the shift.
15. Have a security light and wire into the trailer.
16. Limit key distribution and stamp on all keys "DO NOT DUPLICATE."

17. Jimmy-Proof Type of Locks.
18. Use butt-end hinges or have hinges on the inside.
19. Weld all hasps, use non-retractable screws or use twist off head screws.
20. Conceal hinge butts.
21. Mount hinges and hasps to prevent removal.
22. Alarm doors.
23. Guard dogs.
24. Secure gang boxes so they cannot be removed.
25. Inspect equipment at the end of each day.
26. Have a security check list.
27. Report all theft as soon as possible to local police.
28. Reserve the right to random check personal gang boxes before they are removed from job site.
29. Protect all areas that are 1 square foot or more.
30. Explain National Crime Information Centers.

WELDING, CUTTING AND HEATING

1. Proper precautions for fire prevention shall be taken in areas where welding or other "hot work" is being done (i.e. removing fire hazard from the vicinity and providing a fire watch with an extinguisher on hand during remodel work).
2. Always wear approved tinted eye protection when welding or cutting in areas where welding is being done. See Appendix A.
3. Refer to "Hot Work Procedure" in the "TLC Safety" manual.

HAZARDOUS WASTE DISPOSAL

This procedure is designed to prevent Layton Construction from becoming a generator of hazardous materials and to stay in compliance with the EPA. If there are any questions concerning this policy, call TLC Safety and Environmental Director.

Project which has hazardous substances such as form oil, curing compound diesel, gasoline, solvents, corrosive reactive waste, acids, alkalines, and any other hazardous substance must do the following:

1. Do not return the hazardous waste to the Layton warehouse. TLC will not allow hazardous substances or hazardous wastes to be stored in the storage yard.
2. If the unused hazardous substances are not contaminated and can be used, take them to your next project or find a job site that has need for the hazardous material.

3. If the hazardous substance is not contaminated and you are unable to find a project that can use the substance, call the supplier where you purchased it and they will come and get it.
4. If the hazardous substance is contaminated, call purchasing or the safety director for direction in disposing of the material.
5. Call the supplier and they will come and get the containers as long as they are not contaminated.

STORAGE

1. Place a berm around the area which is large enough to hold the contents being stored.
2. Line the bermed area with a chemical resistant material.
3. Place a 2-inch pipe with a cap on the outside end through the berm to drain off excess water.
4. Place a "No Smoking" sign within 50 feet of the area and have a 20 pound ABC fire extinguisher no closer than 25 feet and no further than 75 feet from the area.

JOB FOREMAN RESPONSIBILITY

THE PHILOSOPHY OF PRODUCTION AND SAFETY MUST BE INSEPARABLE

1. Know and enforce all safety rules and regulations (i.e. TLC Safety and Drug Policies and Company Rules, the Occupational Safety and Health Construction Standards) and all other state and local requirements.
2. Instruct new and existing Employees in safe working practices (JHA, Task training and Stretch & Flex).
3. Ensure all work is performed in a safe manner and that no unsafe condition or equipment exists. The Superintendent is responsible for the safety of all individuals on the project and therefore, personally liable by law for any accident or injury that occurs because of his neglect to safety. **(Contributory Neglect).**
4. See that all personnel protective equipment is available and used.
5. Correct, log and report all unsafe conditions, practices or near misses to the Office. This information will be discussed in the Project Safety Meeting.
6. Be responsible for holding a weekly Safety meeting, teaching or demonstrating safe practices. Discuss unsafe conditions found and the corrections made, near misses, safety training lessons, and any injuries and how to avoid any recurrence. Fill out the Safety Meeting Report, logging attendance, and turn it in to the Office.
7. Secure prompt medical attention for any injured Employee.

“TREAT THE PATIENT AND THEN TREAT THE PAPERWORK”

8. Notify the TLC Safety Department for assistance with all injuries.
9. Report any injury resulting in the loss of consciousness, loss of time or the inability to perform the duties of the injured’s regular job to the Safety Department. Fill out the Notice of Accident and send it to the Safety Department. The Employer’s Report of injury form shall be completed by the Safety Department. Each accident that is defined as recordable must be reported immediately.
10. Notify the Drug Testing Agency and make arrangement for the testing to be performed.
11. Any Employee injured in an accident or any Employee causing an accident must be drug/alcohol tested the same day of the incident.
12. See Appendix L for Company Authorized Doctors.

EMPLOYEE RESPONSIBILITY THE BEST SAFETY EQUIPMENT IN THE WORLD WILL NEVER REPLACE A CAREFUL WORKMAN

1. The direct responsibility of all Employees is that no job can be considered completely finished unless the worker has followed every precaution and safety rule to protect himself and his fellow workers.

“THE PHILOSOPHY OF PRODUCTION AND SAFETY MUST BE INSEPARABLE”

2. Read and acknowledge understanding of TLC’s Safety and Drug Policy and Company rules by signing the tear out slip found in the front of the TLC Safety Handbook and turn it in to the Office. If any questions arise concerning TLC Policy, ask your Superintendent or contact the office. The tear out slip will go into your permanent personal file.
3. Observe all safety rules and regulations (i.e. TLC’s Safety and Drug Policy and Company Rules, the Occupational Safety and Health Construction Standards) and all other state and local safety requirements.
4. Attend a weekly Tool Box Safety Meeting conducted by your foreman and the Project Safety Meeting conducted by the Superintendent or his Safety Technician.
5. Use and maintain all personal safety devices provided.
6. Maintain and properly use all tools under your control.
7. Use proper lifting techniques to avoid strains and sprains. See Appendix E.
8. Correct unsafe conditions and practices and report them along with all near misses to your Superintendent for discussion in the Weekly Safety Meeting.
9. Maintain house keeping continually.
10. No employee is expected to sacrifice anything for safety.
11. Safety is to be an intricate part of your quality control, cost reduction and job efficiency.

REPORTING A WORK-RELATED INJURY/ILLNESS

1. If you feel you have an injury/illness that is work-related, report it to your superintendent or general foreman immediately, and complete necessary reports.
2. If it is determined you need medical treatment, you will be taken to a Company approved Workers Compensation medical provider.
3. If the injury or illness is work-related, DO NOT GO to a medical provider other than one required by the TLC Workers Compensation carrier.
4. If you do go to a provider other than one required by the TLC Workers Compensation carrier for a work-related injury or illness, you will be responsible for payment of treatment received by that provider.
5. The Layton Pocket Safety Handbook lists the TLC Workers Compensation carriers you are required to use.
6. The Superintendent or Foreman will send a report to the Safety Department within 24 hours.

DRUGS AND ALCOHOL

To ensure safe and productive working conditions and consistent with business necessity, the Company prohibits the use, possession, or distribution on its premises, in its work places, or during working time, of any of the following: alcoholic beverages, intoxicants, narcotics, illegal or unauthorized drugs or drug paraphernalia. Company employees shall not report for work under the influence of any illegal or unauthorized drug, alcoholic beverage, intoxicant, narcotic, or other controlled substance. This includes legally prescribed drugs and medicines, which may, in any way, adversely affect employee's working ability, alertness and/or coordination or which may adversely affect the safety of others on the job.

Drug Testing. Consistent with the intent of this policy, the Company reserves the right to drug test potential employees as a condition of employment and thereafter may require randomly selected employees to take drug tests to ensure continuing compliance with the Company's drug policy. The Company also reserves the right to drug test based on reasonable suspicion.

Additionally, employees involved in an accident resulting in an industrial injury/illness or an accident which could have resulted in serious injury, death, or equipment damage, are immediately subject to a mandatory drug test.

Substances Tested. Specifically, our drug testing facilities test for the following substances: Marijuana, Cocaine, Opiates, Barbiturates, Amphetamines, Benzodiazepines, Phencyclidines, Methadone, Propoxyphene, and Alcohol (if post-accident or reasonable suspicion).

Searches. Additionally, the Company reserves the right to search any Company property, facilities or equipment, employee vehicles or other personal property if located on Company property or work sites. The Company may seize any controlled substances and report the same to law enforcement personnel. Refusal to submit to such a search may result in suspension and possible termination.

Prescription Drugs. Legally prescribed drugs may be permitted on Company premises or work locations provided these drugs are contained in the original prescription container and are prescribed by an authorized medical doctor for the current use of the person possessing the drug. It is the responsibility of each employee who is taking prescribed medication to inform his physician of his job duties and to inform his supervisor of any such medication which would restrict him in performing his duties in a safe and efficient manner.

Confidentiality. All information, interviews, reports, statements, memorandums, or test results received by the Company and any of its supervisors will be kept as confidential as possible. Employees may request a written copy of the drug test results, and may, upon request, explain a positive test result in a confidential setting by contacting Human Resources. Further, employees and prospective employees may request a retest of the original sample, at their own expense, by contacting the drug testing facility.

Disciplinary Action for Drug Policy Violations. Any employee who violates this policy, including failing to pass a drug test, refusing to submit to a drug test, or tampering with or adulterating a sample is subject to disciplinary action, including refusal to hire, immediate termination, immediate removal from a work site, and future prohibition from the premises.

Reapplication After Termination for Drug Policy Violation. Former employees, terminated for a first violation of this drug and alcohol policy, may be considered for rehire with the Company after six (6) months. Additionally, the former employee must successfully complete a drug/ alcohol rehabilitation program at the individual's own expense and must successfully pass a drug test. Alternatively, a former employee may be eligible for rehire if a substance abuse professional determines the former employee is not a candidate for a rehab program, and he/she passes a pre-employment drug test. Also, the former employee must make a personal commitment to remain drug free and to abide by this policy. If rehired, such employees may be subject to periodic, unannounced drug testing up to six (6) times within a 12- month period.

After a second non-negative drug test, an employee will be terminated and will not be eligible for rehire.

THINGS TO REMEMBER ABOUT DRUGS

1. The abuse of alcohol and drugs requires an act of will on the part of the user.
2. The Company believes that an individual is responsible for his own actions. Employees are to be held accountable at all times for satisfactory job performance and acceptable work behaviors.
3. TLC reserves the right, in its discretion, to report use, possession or distribution of any illegal substance, or drug named in the Company Drug Policy to law enforcement officials and turn over to the custody of law enforcement officials any such substance or person(s) involved with said substance.

4. When it is determined that an Employee is suffering from an alcohol or drug abuse problem and Management decides to continue the employment of the Employee, the Management's decision to continue employment requires that:
 - a. The Employee recognizes and admits that he/she has an alcohol or drug problem.
 - b. The Employee accepts and understands that if he/she does not correct his/her problem and maintain satisfactory work performance, he/she will be subject to discharge.
 - c. The Employee shows proof that he has successfully completed a Drug Rehabilitation Program.
 - d. Employees of Subcontractors who have an industrial injury or illness which has the potential of being a lost time accident/illness, or will be lost time accident/illness, or damages a piece of equipment such as tipping over a forklift, etc., will be drug tested. If the Employee refuses to be tested or fails the drug test, he/she will be removed from the project.
5. Guidelines for Reasonable Suspicion of Drug Use. If you suspect that an Employee on your project is using drugs or alcohol, and you wish to test them, you should:
 - a. Document the events which led up to the suspicion of the Employee using drugs or alcohol, date and time of occurrences, witnesses, and behavior, actions or physical symptoms of the Employee.
 - b. Make the Employee aware of why he/she is to be tested, because of reasonable suspicion, and the reason behind your decision.
 - c. Screen the Employee as soon as possible. After the test, the employee should be put in a position on the job site where he/she cannot harm themselves or others until the test results are received.
 - d. Make sure the Employee is screened for the correct substance(s): urinalysis for suspicion of drugs, a blood alcohol test for the suspicion of alcohol. Give both screens if you suspect drugs and alcohol.
 - e. Receive the test results from the office before any action is taken.
 - f. For Drug Information Guide, see Appendix N.

SOLICITATION AND DISTRIBUTION OF LITERATURE

To avoid disruption of Company operations and to ensure safe working conditions, the following rules apply to solicitations and distribution of non-Company literature on Company property and at Company work sites:

- Employees may not solicit other employees for membership, contributions, funds, or other purposes during employee's working time, or at any other time if the solicitation interferes with other employees who are scheduled to work.
- Employees may not distribute non-Company literature during working time for any purpose.
- Employees may not distribute non-Company literature (other than Company information) at any time for any purpose in working areas.
- Only employees and suppliers and purveyors of goods and services, who are pre-authorized by the Company, are allowed on Company property and work sites.

Persons who are not employed by the Company may not solicit or distribute non-Company literature on Company property at any time for any purpose.

Working time includes the working time of both the employee doing the soliciting and/or distributing and the employee to whom the soliciting and/or distributing is directed. Working time does not include break periods or meal periods.

Management may authorize the posting of literature to solicit funds for recognized and established charities which benefit the general community.

Employees who violate this policy will be subject to discipline, up to and including termination.

GUIDELINES FOR DISPLAYING FLAGS ON PROJECTS









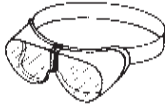

On all job sites with office trailers, Layton Companies will display the American and the Layton Construction Company flags. The Superintendent is responsible for proper care and display of these flags.

The flag should be displayed everyday. Flags will be illuminated by lights mounted on trailers. Please maintain lights in order to display flag at all times. Without lighting, please display during the day only with the flag being raised at the beginning of the workday and lowered at the end of the work shift.

The flag should be raised and lowered by hand and never raised when furled. The flag should never be allowed to touch anything beneath it, such as the ground or floor. When flown at half-staff, the flag should be first hoisted to the peak, then immediately lowered to the half-staff position. It should be raised to the peak again for a moment before it is lowered for the day. When the flag is at half-staff, remove the Layton Construction Company flag because of the clearance between the flag and the trailer at half-staff. No other flag may be flown above the United States flag.

APPENDIX A

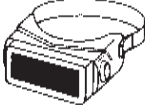
EYE AND FACE PROTECTION

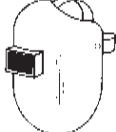
| | | |
|---|---|---|
|  <p>1. Goggles, Flexible Fitting, Regular Ventilation</p> |  <p>2. Goggles, Flexible Fitting, Hooded Ventilation</p> | |
|  <p>3. Goggles, Cushioned Fitting Rigid Body</p> |  <p>4. Spectacles, Metal Frame, with Sideshields</p> | |
|  <p>5. Spectacles, Plastic Frame, with Sideshields</p> |  <p>6. Spectacles, Metal-Plastic Frame, with Sideshields</p> | |
|  <p>7. Welding Goggles, Eyecup Type, Tinted Lenses</p> <p>7a. Chipping Goggles, Eyecup Type, Clear Safety Lenses (Not illustrated)</p> |  <p>8. Welding Goggles, Cover-spec Type, Tinted Lenses</p> <p>8a. Chipping Goggles, Cover-spec Type, Clear Safety Lenses (Not illustrated)</p> | |
|  <p>9. Welding Goggles, Cover-spec Type, Tinted Plate Lens</p> |  <p>10. Face Shield, Available with plastic mesh window)</p> |  <p>11. Welding Helmet</p> |

SAFETY GLASSES AND GOGGLE APPLICATIONS

| Operations | Hazards | Recommended Protectors |
|---|--|--|
| Acetylene - Burning Acetylene - Cutting Acetylene - Welding | Sparks, Harmful Rays, Molten Metal, Flying Particles | 7, 8, 9 |
| Chemical Handling | Splash, Acid Burns, Fumes | 2, 10 (for severe exposure add 10 over 2) |
| Chipping | Flying Particles | 1, 3, 4, 5, 6, 7A, 8A |
| Electric Welding (Arc) | Sparks, Intense Rays, Molten Metal | 9, 11 (11 in combination with 4, 5, 6 in tinted lenses advisable) |
| Furnace Operation | Glare, Heat, Molten Metal | 7, 8, 9 (for severe exposure add 10) |
| Grinding - Light | Flying Particles | 1, 3, 4, 5, 6, 10 |
| Grinding - Heavy | Flying Particles | 1, 3, 7A, 8A (for severe exposure add 10) |
| Laboratory Machining | Chemical Splash, Glass Breakage, Flying Particles | 2 (10 when in combination with 4, 5, 6) 1, 3, 4, 5, 6, 10 |
| Molten Metals | Heat, Glare, Sparks, Splash | 7, 8 (10 in combination with 4, 5, 6, in tinted lenses) |
| Spot Welding | Flying Particles, Sparks | 1, 3, 4, 5, 6, 10 |

APPENDIX B

RIGGINGS

CLIPS AND SPACING FOR SAFE APPLICATION

| Rope Diameter inch | Approximate Weight lb. | Minimum Number Clips for each Rope End | Spacing of Drop Forged Clips inches |
|-----------------------|------------------------------|--|---|
| 3/16 | .10 | 3 | 1-1/8 |
| 1/4 | .19 | 3 | 1-1/2 |
| 5/16 | .29 | 3 | 1-7/8 |
| 3/8 | .47 | 3 | 2-1/4 |
| 7/16 | .70 | 3 | 2-5/8 |
| 1/2 | .78 | 3 | 3 |
| 5/8 | 1.06 | 3 | 3-3/4 |
| 3/4 | 1.59 | 4 | 4-1/2 |
| 7/8 | 2.40 | 4 | 5-1/4 |
| 1 | 2.72 | 5 | 6 |
| 1-1/8 | 3.20 | 6 | 6-3/4 |
| 1-1/4 | 4.50 | 6 | 7-1/2 |
| 1-3/8 | 4.60 | 7 | 8-1/4 |
| 1-1/2 | 5.80 | 7 | 9 |
| 1-5/8 | 7.20 | 7 | 9-3/4 |
| 1-3/4 | 9.50 | 9 | 10-1/2 |
| 2 | 12.50 | 9 | 12 |
| 2-1/4 | 15.50 | 9 | 13-1/2 |
| 2-1/2 | 18.00 | 9 | 15 |

GOOD AND BAD RIGGING PRACTICES

Use of Chokers



Bad
Because of cutting action of eye splice on running line



Bad
Bolt on running line can work loose



Good
No cutting action on running lines



Eye Splices



Bad Practice
Wire rope knot with clip.
Efficiency 50% or less



Bad Practice
Thimble should be used to increase strength of eye and reduce wear on rope



Good Practice
Note use of thimble in eye splice



Good Practice
Use of thimble in eye splice

Hook Slings

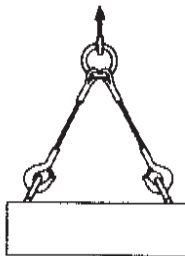

Bad Practice
Hook openings should be turned out

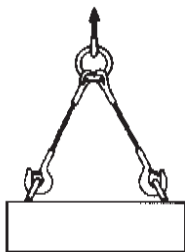

Good Practice
Hooks are turned out



Timber Hitch



Timber Hitch and Half Hitch

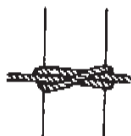

Clove Hitch



Square or
Reef Knot



Sheepshank



Stopper Hitch

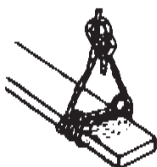

Scaffold Hitch



Bowline

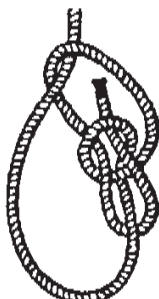

Running Bowline



Becket Knot

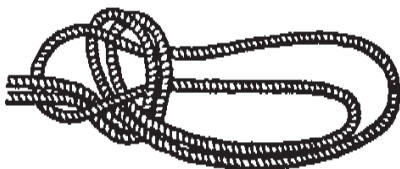

Bowline on a Bight

**RATED CAPACITIES
OF SINGLE AND MULTIPLE LEG SLINGS**

| Rope Diam. Inches | Single Leg | | | Two Leg | | | Three Leg | | | Four Leg | | |
|-------------------------|------------------------------|-----------------|-----------------------------|-----------------------------------|-----|-----|-----------------------------------|-----|-----|-----------------------------------|-----|-----|
| | Straight Vertical Pull | Choker Hitch | Vertical Basket Hitch | Max. Angle Any Leg to Vertical | | | Max. Angle Any Leg to Vertical | | | Max. Angle Any Leg to Vertical | | |
| | | | | 15° | 30° | 45° | 15° | 30° | 45° | 15° | 30° | 45° |
| 1/4 | .56 | .42 | 1 | 1.1 | .97 | .79 | 1.6 | 1.4 | 1.2 | 2.1 | 1.9 | 1.6 |
| 3/8 | 1.2 | .93 | 2.2 | 2.4 | 2.1 | 1.8 | 3.6 | 3.2 | 2.6 | 4.8 | 4.3 | 3.5 |
| 1/2 | 2.2 | 1.6 | 3.9 | 4.2 | 3.8 | 3.1 | 6.3 | 5.7 | 4.6 | 8.4 | 7.6 | 6.2 |
| 5/8 | 3.4 | 2.5 | 6.1 | 6.6 | 5.9 | 4.8 | 9.8 | 8.8 | 7.2 | 13 | 12 | 9.6 |
| 3/4 | 4.9 | 3.6 | 8.8 | 9.4 | 8.4 | 6.9 | 14 | 13 | 10 | 19 | 17 | 14 |
| 7/8 | 6.6 | 4.9 | 12 | 13 | 11 | 9.3 | 19 | 17 | 14 | 25 | 23 | 18 |
| 1 | 8.5 | 6.4 | 15 | 16 | 15 | 12 | 25 | 22 | 18 | 33 | 29 | 24 |
| 1-1/8 | 10 | 7.8 | 19 | 20 | 18 | 15 | 30 | 27 | 22 | 40 | 36 | 29 |
| 1-1/4 | 12 | 9.2 | 23 | 24 | 21 | 17 | 35 | 32 | 26 | 47 | 42 | 34 |
| 1-3/8 | 15 | 11 | 27 | 28 | 25 | 21 | 43 | 38 | 31 | 57 | 51 | 42 |
| 1-1/2 | 17 | 13 | 32 | 34 | 30 | 25 | 51 | 45 | 37 | 67 | 60 | 49 |

**RATED CAPACITIES
6X19 WIRE ROPE**

| Diameter Inches | Circum- ference approx. inches | Weight per ft. approx. lb | | Breaking Strength in tons of 2,000 lb. | | |
|--------------------|---|------------------------------|------|---|------------|------|
| | | Fiber Core | IWRC | XIPS | | IPS |
| | | | | IWRC | Fiber Core | IWRC |
| 1/4 | 3/4 | .015 | .116 | 3.40 | 2.74 | 2.94 |
| 5/16 | 1 | .164 | .180 | 5.27 | 4.26 | 4.58 |
| 3/8 | 1-1/8 | .236 | .26 | 7.55 | 6.10 | 6.56 |
| 7/16 | 1-3/8 | .32 | .35 | 10.2 | 8.27 | 8.89 |
| 1/2 | 1-5/8 | .42 | .46 | 13.3 | 10.7 | 11.5 |
| 9/16 | 1-3/4 | .53 | .59 | 16.8 | 13.5 | 14.5 |
| 5/8 | 2 | .66 | .72 | 20.6 | 16.7 | 17.9 |
| 3/4 | 2-3/8 | .95 | 1.04 | 29.4 | 23.8 | 25.6 |
| 7/8 | 2-3/4 | 1.29 | 1.42 | 39.8 | 32.2 | 34.6 |
| 1 | 3-1/8 | 1.69 | 1.85 | 51.7 | 41.8 | 44.9 |
| 1-1/8 | 3-1/2 | 2.13 | 2.34 | 65.0 | 52.6 | 56.5 |
| 1-1/4 | 3-7/8 | 2.63 | 2.89 | 79.9 | 64.6 | 69.4 |
| 1-3/8 | 4-3/8 | 3.18 | 3.50 | 96.0 | 77.7 | 83.5 |
| 1-1/2 | 4-3/4 | 3.78 | 4.16 | 114 | 92.0 | 98.9 |
| 1-5/8 | 5-1/8 | 4.44 | 4.88 | 132 | 107 | 115 |
| 1-3/4 | 5-1/2 | 5.15 | 5.67 | 153 | 124 | 133 |
| 1-7/8 | 5-7/8 | 5.91 | 6.50 | 174 | 141 | 152 |
| 2 | 6-1/4 | 6.72 | 7.39 | 198 | 160 | 172 |

| SHACKLES | | | | FORGED EYE BOLTS | | | |
|--------------------------------------|-----------------------------------|--------------------------------------|-----------------------------------|----------------------------|--------------------------|--------------------------|--------------------------|
| SCREW PIN ANCHOR TYPE | | | | SHOULDER NUT | | | |
| Normal Shackles Size (Inches) | Working Load Size (Pounds) | Normal Shackles Size (Inches) | Working Load Size (Pounds) | Shank Size (Inches) | 90° to Horizontal | 60° to Horizontal | 45° to Horizontal |
| 3/16 | 600 | 1 | 17,000 | 1/4 | 500 | 175 | 125 |
| 1/4 | 1,000 | 1-1/8 | 19,000 | 5/16 | 800 | 280 | 200 |
| 5/16 | 1,500 | 1-1/4 | 24,000 | 3/8 | 1,200 | 420 | 300 |
| 3/8 | 2,000 | 1-3/8 | 27,000 | 1/2 | 2,200 | 770 | 550 |
| 7/16 | 3,000 | 1-1/2 | 34,000 | 5/8 | 3,500 | 1,225 | 875 |
| 1/2 | 4,000 | 1-3/4 | 50,000 | 3/4 | 5,200 | 1,820 | 1,300 |
| 5/8 | 6,500 | 2 | 70,000 | 7/8 | 7,200 | 2,250 | 1,800 |
| 3/4 | 9,500 | 2-1/4 | 80,000 | 1 | 10,000 | 3,500 | 2,500 |
| 7/8 | 13,000 | 2-1/2 | 110,000 | 1-1/4 | 15,200 | 5,320 | 3,800 |
| | | | | 1-1/2 | 21,400 | 7,490 | 5,350 |

WIRE ROPE SLINGS
6 X 19 OR 6 X 37 IWRC IPS

| Rope Diameter (Inches) | Vertical (1) | Choker (1) | Vertical Basket (2) | 60° to Horizontal | 45° to Horizontal | 30° to Horizontal | Rope Diameter (Inches) |
|-------------------------------|---------------------|-------------------|----------------------------|--------------------------|--------------------------|--------------------------|-------------------------------|
| 1/4 | 1,120 | 840 | 2,200 | 1,940 | 1,580 | 1,120 | 1/4 |
| 3/8 | 2,400 | 1,860 | 5,000 | 4,200 | 3,600 | 2,400 | 3/8 |
| 1/2 | 4,400 | 3,200 | 8,800 | 7,600 | 6,200 | 4,400 | 1/2 |
| 5/8 | 6,800 | 5,000 | 13,600 | 11,800 | 9,600 | 6,800 | 5/8 |
| 3/4 | 9,800 | 7,200 | 19,400 | 16,800 | 13,800 | 9,800 | 3/4 |
| 7/8 | 13,200 | 9,800 | 26,000 | 22,000 | 18,600 | 13,200 | 7/8 |
| 1 | 17,000 | 12,800 | 34,000 | 30,000 | 24,000 | 17,000 | 1 |
| 1-1/8 | 20,000 | 15,600 | 42,000 | 36,600 | 30,000 | 20,000 | 1-1/8 |
| 1-1/4 | 24,000 | 18,400 | 48,000 | 42,000 | 34,000 | 24,000 | 1-1/4 |
| 1-3/8 | 30,000 | 22,000 | 58,000 | 50,000 | 42,000 | 30,000 | 1-3/8 |
| 1-1/2 | 34,000 | 26,000 | 70,000 | 60,000 | 50,000 | 34,000 | 1-1/2 |
| 1-5/8 | 40,000 | 30,000 | 82,000 | 70,000 | 58,000 | 40,000 | 1-5/8 |
| 1-3/4 | 48,000 | 36,000 | 94,000 | 82,000 | 66,000 | 48,000 | 1-3/4 |
| 2 | 60,000 | 46,000 | 122,000 | 106,000 | 86,000 | 60,000 | 2 |

ALLOY CHAIN SLINGS WORKING LOAD LIMITS*

| Size of Chain | | Single Chain Lbs. at 90° | Double Chain Sling/lbs. Type D | | | Triple and Quad Chain Slings/lbs. Type T and Type Q | | |
|---------------|----|--------------------------|--------------------------------|--------|--------|---|---------|--------|
| Inches | mm | | | | | | | |
| 9/32 | 7 | 3,500 | 6,050 | 4,950 | 3,500 | 9,100 | 7,400 | 5,250 |
| 3/8 | 10 | 7,100 | 12,300 | 10,000 | 7,100 | 18,500 | 15,000 | 10,600 |
| 1/2 | 13 | 12,000 | 20,800 | 17,000 | 12,000 | 31,200 | 25,000 | 18,000 |
| 5/8 | 16 | 18,000 | 31,300 | 25,600 | 18,000 | 47,000 | 38,400 | 27,200 |
| 3/4 | 20 | 28,300 | 49,000 | 40,000 | 28,300 | 73,500 | 60,000 | 42,500 |
| 7/8 | 22 | 34,300 | 59,400 | 48,500 | 34,000 | 89,100 | 72,800 | 51,500 |
| 1 | 26 | 38,750* | 67,000 | 54,800 | 38,750 | 100,600 | 82,200 | 58,200 |
| 1-1/4 | 32 | 57,500* | 99,600 | 81,300 | 57,500 | 149,400 | 122,000 | 86,300 |

Important: Working Load Limit should not be exceeded. Ratio 4 to 1

*Values shown for these sizes are Grade 63 embossed "A" only.

SYNTHETIC WEB SLINGS

HEAVY DUTY 8000 LBS. WEBBING — SINGLE PLY TRIANGLE

| Sling body width (Inches) | Vertical | Choker | Vertical Basket | 60° Basket | 45° Basket | 30° Basket |
|---------------------------|----------|--------|-----------------|------------|------------|------------|
| 1 | 1,600 | 1,200 | 3,200 | 2,720 | 2,240 | 1,600 |
| 2 | 3,200 | 2,400 | 6,400 | 5,440 | 4,480 | 3,200 |
| 3 | 4,800 | 3,600 | 9,600 | 8,160 | 6,720 | 4,800 |
| 4 | 6,400 | 4,800 | 12,800 | 10,880 | 8,960 | 6,400 |
| 5 | 8,000 | 6,000 | 16,000 | 13,600 | 11,200 | 8,000 |
| 6 | 9,600 | 7,200 | 19,200 | 16,320 | 13,440 | 9,600 |

Notes:

1. All angles shown are measured from the horizontal.
2. Capacities for intermediate widths not shown may be obtained by interpolation.

CONCRETE REINFORCING STEEL

| WEIGHT & DIMENSIONS ASTM STANDARD REINFORCING BARS | | | |
|---|-----------------------------|--------------------|-----------------------------------|
| Bar Size Designation | Weight Pounds per Ft. | Normal Dimensions | |
| | | Diameter Inches | CrossSectionalAreas Sq. Inches |
| #3 | 0.376 | 0.375 | 0.11 |
| #4 | 0.668 | 0.500 | 0.20 |
| #5 | 1.043 | 0.625 | 0.31 |
| #6 | 1.502 | 0.750 | 0.44 |
| #7 | 2.044 | 0.875 | 0.60 |
| #8 | 2.670 | 1.000 | 0.79 |
| #9 | 3.400 | 1.128 | 1.00 |
| #10 | 4.303 | 1.270 | 1.27 |
| #11 | 5.313 | 1.410 | 1.56 |
| #14 | 7.650 | 1.693 | 2.25 |
| #18 | 13.600 | 2.257 | 4.00 |
| | | | |

WEIGHT OF METALS PER SQUARE FOOT

| Thickness in Inches | Weights, Pounds per Square Foot | | | |
|---------------------------|---------------------------------|--------------|--------|--------|
| | Wrought Iron | Cast Iron | Steel | Copper |
| 1/16 | 2.50 | 2.34 | 2.55 | 2.89 |
| 1/8 | 5.00 | 4.68 | 5.10 | 5.79 |
| 3/16 | 7.50 | 7.03 | 7.65 | 8.68 |
| 1/4 | 10.00 | 9.38 | 10.25 | 11.60 |
| 5/16 | 12.50 | 11.70 | 12.80 | 14.50 |
| 3/8 | 15.00 | 14.10 | 15.30 | 17.40 |
| 7/16 | 17.50 | 16.40 | 17.90 | 20.30 |
| 1/2 | 20.00 | 18.70 | 20.40 | 23.20 |
| 9/16 | 22.50 | 21.10 | 23.00 | 26.00 |
| 5/8 | 25.00 | 23.50 | 25.50 | 28.90 |
| 11/16 | 27.50 | 25.80 | 28.10 | 31.80 |
| 3/4 | 30.00 | 28.10 | 30.60 | 34.70 |
| 13/16 | 32.50 | 30.50 | 33.20 | 37.60 |
| 7/8 | 35.00 | 32.80 | 35.70 | 40.50 |
| 15/16 | 27.50 | 35.20 | 38.30 | 43.40 |
| 1 | 40.00 | 37.50 | 40.80 | 46.30 |
| Cu. Ft. 12" | 480.00 | 450.00 | 489.60 | 555.60 |

COMMON METRIC EQUIVALENTS*

| | | |
|---------------------------|---------|-------------------|
| 1 inch | 25.400 | millimeters |
| 1 foot | 0.300 | meters |
| 1 yard | 0.910 | meters |
| 1 mile | 1.610 | kilometers |
| 1 square inch | 6.450 | centimeters |
| 1 square foot | 0.090 | square meters |
| 1 square yard | 0.860 | square meters |
| 1 cubic inch | 16.307 | cubic centimeters |
| 1 cubic foot | 0.030 | cubic meters |
| 1 cubic yard | 0.760 | cubic meters |
| 1 quart | 0.950 | liters |
| 1 gallon | 0.004 | cubic meters |
| 1 ounce | 28.350 | grams |
| 1 pound | 0.450 | kilograms |
| 1 horsepower | 0.750 | kilowatts |
| 1 millimeter | 0.040 | inches |
| 1 meter | 3.280 | feet |
| 1 meter | 1.090 | yards |
| 1 kilometer | 0.620 | miles |
| 1 square centimeter | 0.160 | square inches |
| 1 square meter | 10.760 | square feet |
| 1 square meter | 1.200 | square yards |
| 1 cubic centimeter | 0.060 | cubic inches |
| 1 cubic meter | 35.310 | cubic feet |
| 1 cubic meter | 1.310 | cubic yards |
| 1 cubic meter | 264.200 | gallons |
| 1 liter | 1.060 | quarts |
| 1 gram | 0.040 | ounces |
| 1 kilogram | 2.200 | pounds |
| 1 kilowatt | 1.340 | horsepower |

*closest approximation

DECIMAL EQUIVALENTS OF AN INCH

| | | | |
|-------|---------|--------|---------|
| 1/64 | .015625 | 33/64 | .515625 |
| 1/32 | .03125 | 17/32 | .53125 |
| 3/64 | .046875 | 35/64 | .546875 |
| 1/16 | 0.625 | 9/16 | .5625 |
| 5/64 | 0.78125 | 37/64 | .578125 |
| 3/32 | .09375 | 19/32 | .59375 |
| 7/64 | .109375 | 39/64 | .609375 |
| 1/8 | .125 | 5/8 | .625 |
| 9/64 | .140625 | 41/64 | .640625 |
| 5/32 | .15625 | 21/32 | .65625 |
| 11/64 | .171875 | 43/64 | .671875 |
| 3/16 | .1875 | 11/16 | .6875 |
| 13/64 | .203125 | 45/64 | .703125 |
| 7/32 | .21875 | 23/32 | .71875 |
| 15/64 | .234375 | 47/64 | .734375 |
| 1/4 | .25 | 3/4 | .75 |
| 17/64 | .265625 | 49/64 | .765625 |
| 9/32 | .28125 | 25/32 | .78125 |
| 19/64 | .296875 | 51/64 | .796875 |
| 5/16 | .3125 | 13/16 | .8125 |
| 21/64 | .328125 | 53/64 | .828125 |
| 11/32 | .34375 | 27/32 | .84375 |
| 23/64 | .359375 | 55/64 | .859375 |
| 3/8 | .375 | 7/8 | .875 |
| 25/64 | .390625 | 57/64 | .890625 |
| 13/32 | .40625 | 29/32 | .90625 |
| 27/64 | .421875 | 59/64 | .921875 |
| 7/16 | .4375 | 15/16 | .9375 |
| 29/64 | .45125 | 61/64 | .95125 |
| 15/32 | .46875 | 31/32 | .96875 |
| 31/64 | .484375 | 363/64 | .984375 |
| 1/2 | .5 | | .5 |

WEIGHTS AND MEASURES

HANDY THINGS TO KNOW

To Find:

- The circumference of a circle, multiply the diameter by 3.1416.
- The diameter of a circle, multiply the circumference by .31831.
- The area of a circle, multiply the square of the diameter by .7854.
- The area of a triangle, multiply the base by 1/2 the perpendicular height
- The volume of a sphere, multiply the cube of the diameter by .5236.

A gallon of water weighs 8-1/2 pounds and contains 231 cubic inches.

A cubic foot of water contains 7-1/2 gallons, 1,728 cubic inches and weighs 62-1/2 pounds.

One atmosphere = 33.899 feet of water at 39...F.

One atmosphere = 760 mm of mercury.

One atmosphere = 14.7 pounds per square inch.

Capacity of Cylindrical Tanks - U.S. Gallons and Barrels (Petroleum) per foot of length or height.

$$\frac{\pi D^2 \times 7.481}{4}$$

Capacity per foot, U.S. gallon =

In board measure all boards are assumed to be 1 inch thick. Area of a linear foot multiplied by length in feet will give the surface contents in square feet.

RULES OF THUMB

The following are not suggested as substitutes for accurate tables and reference material, but are sometimes useful in making a final safety check.

Nails

Safe load lateral resistance in pounds equal (8) times the pennyweight.

1-6d nail = 8 x 6, or 48 pounds

1-10d nail = 8 x 10, or 80 pounds

Manila Rope

Safe load in tons equal diameter in inches squared. Not accurate in sizes larger than one inch (1").

1" rope = 1 x 1, or 1 ton safe load

1/2" rope = 1/2 x 1/2, or 1/4 ton safe load

For sisal rope, decrease safe load by one-third

Plow-steel Cable

Safe load in tons is eight (8) times the diameter in inches squared.

1/2" cable = 1/2 x 1/2 = 1/4 x 8 = 2 tons

Open Eye Hook

Safe load in tons is diameter of eye in inches squared.

2" hook, 2 x 2 = 4 tons

Shackle

Safe load in tons is diameter of pin in one-fourth inches (1/4") squared and divided by three (3).

1/2" diameter = 2 quarters

$\frac{2 \times 2}{3} = 1\text{-}1/3$ tons or 2,667 pounds



Chains



Safe load in tons in six (6) times the square of the diameter of chain stock.

1/2" diameter chain stock

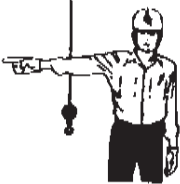
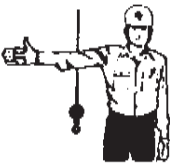
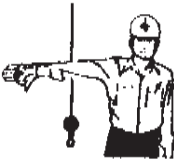
1/2 x 1/2 x 6 = 1-1/2 tons or 3,000 pounds

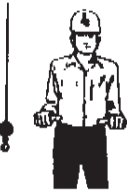











**RECOMMENDED HAND SIGNALS FOR
CONTROLLING CRANE OPERATIONS**
(continued)

| | | |
|--|--|--|
|  <p>SWING: Arm extended, point with finger in direction of swing of boom.</p> |  <p>RAISE THE BOOM AND LOWER THE LOAD: With arm extended thumb pointing up, flex fingers in and out as long as load movement is desired.</p> |  <p>LOWER THE BOOM AND RAISE THE LOAD: With arm extended thumb pointing down, flex fingers in and out as long as load movement is desired.</p> |
|  <p>TRAVEL: (Rail mount or trolley) arm extended forward, hand open and slightly raised, making pushing motion in direction of travel.</p> |  <p>EXTEND BOOM: (Telescoping booms) Both fists in front of body with thumbs pointing outward.</p> |  <p>RETRACT BOOM: (Telescoping booms) Both fists in front of body with thumbs pointing toward each other.</p> |

| | |
|---|---|
|  <p>TRAVEL: Arm extended forward, hand open and slightly raised, making pushing motion in direction of travel.</p> |  <p>TRAVEL: (One track, Lock the track on side indicated by raised fist. Travel opposite track in direction indicated by circular motion of other fist, rotated vertically in front of body. (For crawler cranes only)</p> |
|---|---|

APPENDIX D

CONCRETE PUMP HAND SIGNALS

| | | | |
|--|---|---|---|
|  <p>1.</p> |  <p>2.</p> |  <p>3.</p> |  <p>4.</p> |
| BOOM UP | BOOM DOWN | BOOM LEFT | BOOM RIGHT |
|  <p>5.</p> |  <p>6.</p> |  <p>7.</p> |  <p>8.</p> |
| OPEN OR EXTEND BOOM | CLOSE OR RETRACT BOOM | STOP BOOM | START PUMP SPEED UP |
|  <p>9.</p> |  <p>10.</p> |  <p>11.</p> |  <p>12.</p> |
| SLOW PUMP DOWN | STOP PUMP | LITTLE BIT | ADD WATER 4-GALLONS |
|  <p>13.</p> | | | |
| ALL DONE CLEAN UP | | | |

APPENDIX E

LIFTING CORRECTLY

MENTAL LIFTING

- 1. Lifting Everything Twice.**
 - First lift the load mentally.
 - Plan every step carefully before you do it physically.
- 2. Size up the Load**
 - How much does it weight?
 - How much do you weight?
 - Can you lift it safely?
- 3. Get Help**
 - If the load is too bulky or heavy get help, don't do it alone.
- 4. Find a Better Way**
 - If the load is to large and heavy, arrange for mechanical help such as a pushcart, hand truck, wheelbarrow, forklift or crane.
 - Anticipate problems you may encounter.
- 5. Check the Pathway**
 - Look for obstacles that might cause you to trip, slip, or fall.
 - Check lifting, traffic (people and vehicles), and changes in elevation.
- 6. Solve Repetitive Problems**
 - Look for ways to reduce the number of times you have to lift.
 - Don't lift and twist in the same motion.
 - Use mechanical means whenever possible.

PHYSICAL LIFTING

Be sure to apply proper lifting techniques when working alone or as a team.

- 1. Lift it Properly**
 - Keep your back straight; tuck in your chin.
 - Place your feet apart, one ahead of the other.
 - Grip load with palm and fingers, not fingers alone.
 - Bring load close to your body by tucking elbows in.
 - Lift with your legs and arms, not your back.
 - Compress your stomach muscles.
 - Keep a clear view over load as you lift.

APPENDIX F FIRE EXTINGUISHERS

| | WATER TYPE | | | | FOAM | CARBON DIOXIDE | SODIUM OR POTASSIUM DICARBONATE | | DRY CHEMICAL | | |
|---|----------------------------------|---|--|--|-----------------------------|------------------------|--|---|---|---|--|
| | STORED PRESSURE | CARTRIDGE OPERATED | WATER PUMP TANK | SODA ACID | | | FOAM | CO ² | GARTRIDGE OPERATED | STORED PRESSURE | STORED PRESSURE |
| CLASS A FIRES WOOD PAPER TRASH HAVING GLOWING EMBERS A ORDINARY COMBUSTIBLES | YES | YES | YES | YES | YES | NO | NO | NO | YES | YES | |
| CLASS B FIRES FLAMMABLE LIQUIDS GASOLINE, OIL PAINT, GREASE, ETC. B FLAMMABLE LIQUIDS | NO | NO | NO | NO | YES | YES | YES | YES | YES | YES | |
| CLASS C FIRES ELECTRICAL EQUIPMENT C ELECTRICAL EQUIPMENT | NO | NO | NO | NO | NO | YES | YES | YES | YES | YES | |
| CLASS D FIRES COMBUSTIBLE METALS D COMBUSTIBLE METALS | NO | NO | NO | NO | NO | YES | YES | YES | YES | YES | |
| SPECIAL EXTINGUISHING AGENTS APPROVED BY RECOGNIZED TESTING LABORATORIES | | | | | | | | | | | |
| METHOD OF OPERATION | PULL PIN SQUEEZE HANDLE | TURN UPSIDE DOWN AND BUMP | PUMP HANDLE | TURN UPSIDE DOWN | TURN UPSIDE DOWN | PULL PIN SQUEEZE LEVER | RUPTURE CARTRIDGE SQUEEZE LEVER | PULL PIN SQUEEZE HANDLE | PULL PIN SQUEEZE HANDLE | PULL PIN SQUEEZE HANDLE | RUPTURE CARTRIDGE SQUEEZE LEVER |
| RANGE | 30' - 40' | 30' - 40' | 30' - 40' | 30' - 40' | 30' - 40' | 3' - 8' | 5' - 20' | 5' - 20' | 5' - 20' | 5' - 20' | 5' - 20' |
| MAINTENANCE | CHECK AIR PRESSURE GAUGE MONTHLY | WEIGH GAS CARTRIDGE AND FILL IF REQUIRED ANNUALLY | DISCHARGE AND FILL WITH WATER ANNUALLY | DISCHARGE AND FILL WITH WATER ANNUALLY | DISCHARGE ANNUALLY RECHARGE | WEIGH SEMI ANNUALLY | WEIGH GAS CARTRIDGE CHECK CONDITION OF DRY CHEMICAL ANNUALLY | CHECK PRESSURE GAUGE AND CONDITION OF DRY CHEMICAL ANNUALLY | CHECK PRESSURE GAUGE AND CONDITION OF DRY CHEMICAL ANNUALLY | CHECK PRESSURE GAUGE AND CONDITION OF DRY CHEMICAL ANNUALLY | WEIGH GAS CARTRIDGE CHECK CONDITION OF DRY CHEMICAL ANNUALLY |

APPENDIX G

HOW TO USE CONTAINER LABELS AND MSDS'S

HOW LABELS COMMUNICATE

Labels come in many formats. Some labels use words to describe the hazards and some use numbers and colors to help you quickly identify the kind and degree of hazard the chemical could present.

The labels you see may look slightly different from the samples we'll describe here, but they should have the same basic information.

ALWAYS READ THE LABEL FIRST

Always read the label before you move, handle, or open a chemical container. It has a lot of valuable information and instructions.

WHAT'S ON THE LABEL?

The label should always tell you:

- The name of the chemical.
- The name and address of the company that made or imported the chemical.
- The chemical's health hazards.

The label might also include:

- Important instructions for storing or handling the chemical.
- Protective clothing and equipment you should use when working with the chemical.
- Suggested safety procedures.

A LABEL TELLS YOU

The name of the chemical — the common name, chemical name, or both. If the substance contains more than one chemical, they will all be listed.

The name, address, and emergency telephone number of the company that manufactured or imported the chemical.

The chemical's physical hazards. What could happen if you don't handle it properly! Is it flammable, combustible, or explosive? Is it reactive or Radioactive?

The chemical's health hazards. The possible health problems that could result from over exposure. Is it toxic? An irritant? Could it cause cancer?

Some labels also include important information such as storage and handling instructions. This could include information like "use only in well ventilated areas", or "store in tightly closed containers".

Basic protective clothing. Equipment and procedures that could be used to work safely with the chemical might also be listed. Here you might be told to "avoid contact with skin", or to use eye protection, etc.

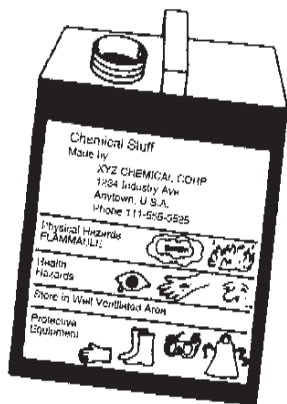

UNDERSTANDING LABELS

Chemical manufacturers, importers, and distributors must be sure that containers of hazardous chemicals shipped to their customers are labeled, tagged or marked with the identity, appropriate hazard warnings and the name and address of the manufacturer or responsible party.

Labels come in all shapes and sizes. The color bar type is one popular type of label.

Become familiar with the labels, symbols and numbers. Understand what they mean. It can help you avoid an accident.

COLOR BAR LABEL

NAME of chemical and the ADDRESS of the manufacturer, importer or distributor of the chemical.

Potential impact on HEALTH.

FLAMMABILITY: how easily the chemical burns.

REACTIVITY: what conditions and other chemicals the chemical can react with.

Any special protective equipment which should be worn or used.

Colors indicate the kind of Hazard

Red = FIRE
Yellow = REACTIVE
Blue = HEALTH HAZARD

The numbers show the degree or severity of that hazard:

0 = Minimal; 1 = Slight Hazard; 2 = Moderate Hazard
3 = Serious Hazard; 4 = Severe Hazard

| | |
|--------------------------------|--------|
| Chemical Name MFG • Address | |
| Health | Blue |
| Flammability | Red |
| Reactivity | Yellow |
| Personal Protection | White |

NFPA TYPE PANEL LABEL

The National Fire Protection Agency label is another label type which also tells you a lot about the chemical it represents. The following tells you what the numbers and symbols mean.

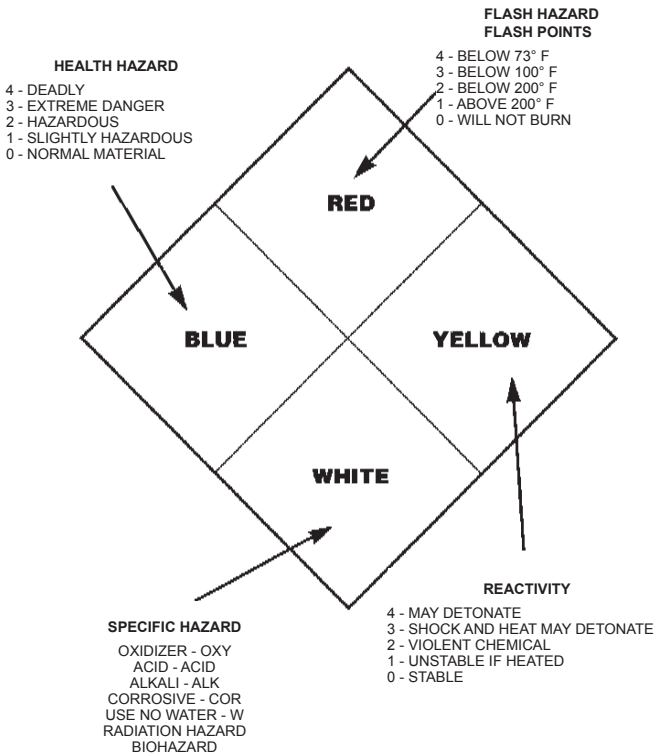

WHAT IS A MATERIAL SAFETY DATA SHEET?

The Material Safety Data Sheet (MSDS) is the backbone of hazard communications. It gives details on chemical ingredients, chemical dangers, emergency response direction, and safety procedures. LCC has at least one MSDS for every hazardous chemical in the workplace. The following example illustrates the basic information contained in a MSDS. Section numbers and headings can vary because there is no standard format requirement by OSHA.

1. Section 1 covers: Who makes the chemical, address, emergency phone numbers, trade names, and (in most cases) the formula. When the formula is a trade secret, it is not disclosed, but the MSDS will still provide information on hazards and measures for safe handling.

2. Chemical identification of components as well as exposure limit guidelines provided by ACGIH-TLV, and PSHA-PEL are given in Section 2.

3. Physical Data includes: Appearance and odor under normal conditions, specific gravity, boiling point, vapor pressure, vapor density, and evaporation rate.

4. Fire and Explosion: Indicates what kind of fire extinguisher to use, the flash point (temperature at which material ignites), special fire fighting procedures, and any special dangers.

1. ACGIH-TLV = American Conference of Government Industrial Hygienists - Threshold Limit Value

2. OSHA - PEL = Occupational Health and Safety Administration - Permissible Exposure Limit

MATERIAL SAFETY DATA SHEET

SECTION 1

| | |
|-----------------|--------------------------|
| MFG | Emergency Phone # |
| Address | Trade Name |
| Chemical | Formula |

SECTION 2

HAZARDOUS INGREDIENTS

SECTION 3

PHYSICAL DATA

| | |
|----------------------------|-------------------------|
| Appearance | Odor |
| Boiling Point | Specific Gravity |
| Vapor Pressure | Percent Volatile |
| Vapor Density | Evaporation Rate |
| Solubility in Water | |

SECTION 4

FIRE AND EXPLOSION DATA

Flash Point
Fire Extinguisher Media
Special Fire Fighting Procedures
Unusual Fire Hazards
Flammability Limits (by volume)

5. Section 5 tells you what the chemical will react with, and if it does react, what might happen. It also tells you what situations to avoid so you don't get an unexpected chemical reaction.

6. Entry

How the chemical can enter your body is covered in Section 6.

This can include:

- Inhalation through the nose
- Eye contact
- Skin contact
- Through mouth

Effect - what the symptoms might be

- Eye irritation
- Rashes on skin
- Faintness
- Headache
- Nausea
- Irregular heart beat
- Aggravation of existing medical condition
- Dizziness

First Aid

If the chemical is swallowed, inhaled or comes in contact with eyes or skin, this section of the MSDS gives emergency first aid procedures to follow:

7. This section covers what you should do if there is a spill or leak:

- What to do if there is a leak/spill.
- Equipment and procedures for cleaning up the spill.
- Method of disposal/special precautions.

8. **Special Protection**

To reduce the risk of harmful exposure, Section 8 provides safety measures for adequate protection. You will find out what type of protection is required.

- Gloves
- Respirator
- Ventilation
- Eye Protection
- Protective Clothing

9. **Special Precautions**

Covers, special handling requirements like temperature, open sparks, humidity, and special containers. Some chemicals may require storage in special cabinets or refrigeration.

CHEMICAL LABELS

In addition to the Material Safety Data Sheet, the Hazard Communication Standards requires that the containers be properly labeled in the workplace and that your employer train you in how to read the labels and what special precautions are required.

The label may use words and/or symbols...



...to describe protective clothing which should be used when handling the chemical. The label should identify the chemical, the manufacturer, hazard severity, health hazard, and protective equipment needed.

Portable containers intended for immediate use (by employee who makes the transfer) and pipes are not required.

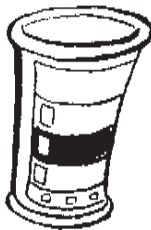

APPENDIX H

LADDERS

COMMON SENSE

- Place ladder on solid secure footing.
- Extend ladder when no one is on it.
- Adjust the length of an extension ladder only when your eye level is below level of locking devices so you can see when lock in engages.
- Always face the ladder when going up or down.
- Take one step at a time.
- Carry tools or other materials in tool pockets or attached to a tool belt.
- Raise and lower heavy materials with a rope.

Right

Wrong

Vertical
Height

1/4 Vertical
Height

- Move ladder to where work can be done without reaching far to either side of ladder.
- Keep the bottom of ladder free of materials, traffic, swingign doors, etc.
- Never leave ladders upright and unattended if children are around.
- Do not use ladders as guys, braces, gin poles, skids, scaffolds, etc. or substitute for any use other than intended purposes.
- Never repair a ladder with improvised parts or techniques.

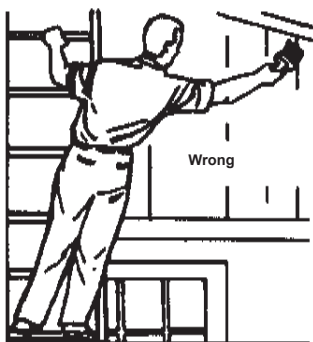

LADDERS MADE ON THE JOB

Manufactured ladders ("code" ladders) should comply with state and federal safety codes and standards.

Metal or other conductive ladders should be prohibited where the ladder or a worker using the ladder might come within 4 feet of electrical wiring or equipment.

Ladders placed where they could be moved or knocked over, should be protected by barriers or guards.

LIGHT TRADES LADDERS REQUIREMENTS FOR

| Length in feet | Rails in inches | Rungs in inches |
|---------------------------|----------------------------|----------------------------|
| Up to 12 | 2 x 3 | 1 x 3 |
| 12 - 20 | 2 x 4 | 1 x 3 |
| 20 - 26 | 2 x 6 | 1 x 4 |

Maximum Single Cleat • Maximum length - 24 feet
Width at top 15" minimum, 20" maximum

LADDERS MADE ON THE JOB

Approved Construction

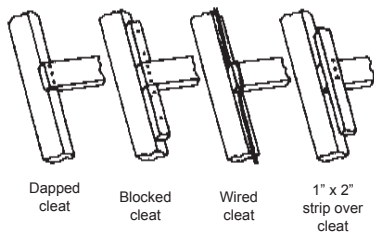

Dapped cleat

Blocked cleat

Wired cleat

1" x 2" strip over cleat

Not Approved

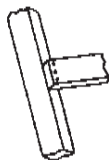

cleat flush

SECURED LADDERS

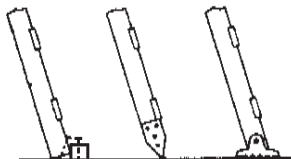

Nailed or cleated

Non slip feet

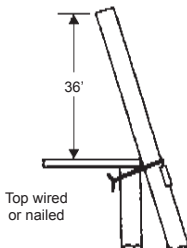

Top wired or nailed

Double Cleat Ladder

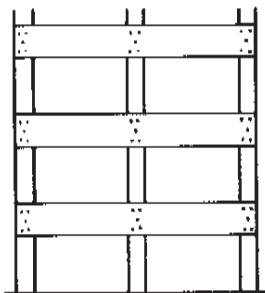

Maximum length - 24 feet
 Rails - 2" x 6" minimum
 Rungs - 1" x 4" minimum

Recommended safe angle for portable ladders

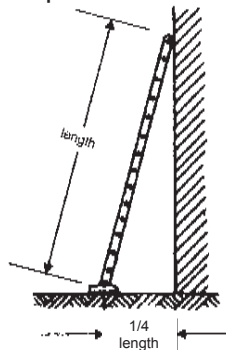

MIDRAIL STANDARD

2-1" X 4"

or
1-2" X 4"

2" X 4"

42" - 45"

Midrail
1" X 6"
minimum

Toeboard
1" X 6"
minimum

Use material such as 2" x 4" or equivalent that will support 200 lbs. in each direction. The posts shall not be more than 8 ft. apart. If using double hooded rails make certain the nail is driven all the way in.

SAFE ANGLES FOR LADDERS, STAIRS AND RAMPS

90°

Fixed ladders
with rungs or
cleats preferred

75°

Stepladders or railed
ladders with treads
preferred

50°

Nosing 37°

30 to 34
inches

Run

Riser 30°

18°

7°

Preferred

0°

RUNS AND RISERS FOR STAIRS

(Run + Riser = 17-1/2")

| Angle with Horizontal | Riser Inches | Run Inches |
|-----------------------|--------------|------------|
| 30° - 35° | 6-1/2 | 11 |
| 32° - 08° | 6-3/4 | 10-3/4 |
| 33° - 41° | 7 | 10-1/2 |
| 35° - 16° | 7-1/4 | 10-1/4 |
| 36° - 52° | 7-1/2 | 10 |
| 38° - 29° | 7-3/4 | 9-3/4 |
| 40° - 08° | 8 | 9-1/2 |
| 41° - 44° | 8-1/4 | 9-1/4 |
| 43° - 22° | 8-1/2 | 9 |
| 45° - 00° | 8-3/4 | 8-3/4 |
| 46° - 38° | 9 | 8-1/2 |
| 48° - 16° | 9-1/4 | 8-1/4 |
| 49° - 54° | 9-1/2 | 8 |

PLATFORMS & STAIRWAYS

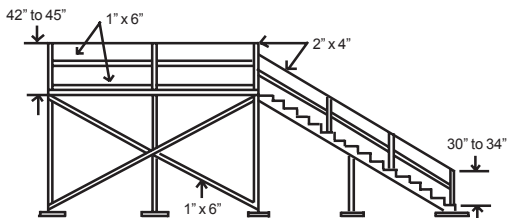

APPENDIX I

PROTECTIVE TROUGH FOR PROTRUDING REINFORCING STEEL

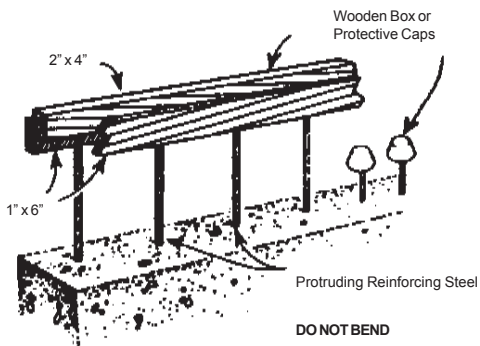

You may also tie a piece of rebar or wood next to the top, whatever you use make certain it guards against impalement, when working above rebar fall protection must be provided.

APPENDIX J

WHAT IS NOISE?

Noise is unwanted sound around us.

Noise can be generated from recreational activities: shooting, car racing, boating, etc.

Noise is also generated by many activities we perform around the house.

- Lawn mowing
- Chain sawing
- Vacuuming, etc.

We also have noise from our work activities:

- Air hammering
- Saws
- Punch presses
- Grinding, etc.

All noise can permanently decrease your ability to hear depending on how long, how loud and how often you are exposed.

HOW DOES YOUR EAR WORK?

Your outer ear consists of the Pinna and Auditory Canal. The Pinna and the canal collect and funnel sound waves generated in your environment to your ear drum.

Behind the eardrum, in the Middle Ear, are the three smallest bones in your body. These bones are called Ossicles. The Ossicles pick up vibrations from the eardrum and transmit them to the Inner Ear.

The Inner Ear consists of fluid-filled passages containing thousands of microscopic nerve fibers, which respond specifically to the vibration entering the ear.

Impulses from these nerve fibers are sent to your brain and are registered as sound.

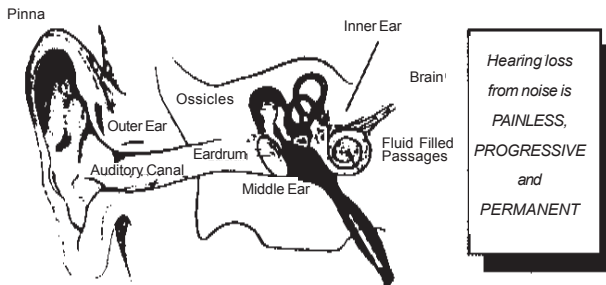

HOW DOES NOISE AFFECT YOUR HEARING?

Hearing loss occurs when the microscopic nerve fibers in the inner ear are damaged by prolonged exposure to excessive noise. This noise exposure can be on the job or off.

The hearing loss from noise occurs very slowly - first destroying the nerve fibers necessary for hearing high frequency sounds and gradually destroying nerve fibers necessary for hearing speech sounds.

Hearing loss from noise is, **PAINLESS, PROGRESSIVE AND PERMANENT!**

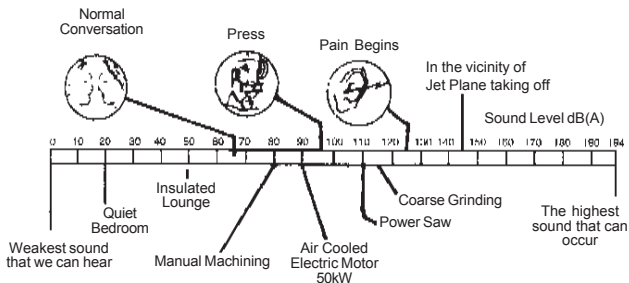

APPENDIX K

EMERGENCY CARE GUIDE ACTIONS IMMEDIATELY FOLLOWING INJURIES HAVE SAVED LIVES - KNOW WHAT TO DO

CPR and first aid are often required when an emergency occurs.

Stop and assess the accident scene. Make sure you are not putting yourself in a dangerous situation.

IMMEDIATE ACTION

1. **BREATHING AND CIRCULATION:** If adult victim is not breathing, have someone call for help or call for help yourself before beginning mouth-to-mouth resuscitation. Begin CPR only if there is no pulse.
2. **BLEEDING:** Apply direct pressure at the wound and elevate it to stop persistent bleeding.
3. **SHOCK:** Lay the victim on his/her back and give assurance. Position the feet above the head. Monitor breathing and circulation.

If neck or spinal injuries are evident or suspected move the victim only if:

- a. It is necessary to establish or maintain a vital function such as breathing, or
- b. It must be done to avoid further injury.

FOLLOW-UP ACTIONS

1. **STAY CALM YOURSELF.**
2. **PROFESSIONAL MEDICAL HELP.** Have someone summon professional help unless you are alone with an unresponsive, unconscious adult victim. Then activate the Emergency Medical System (usually 911) before beginning rescue breathing.

3. **FOOD AND LIQUIDS.** Never give unconscious or semiconscious victims food or liquids. They cannot swallow and might suffocate.
4. **OTHER HEALTH PROBLEMS.** Check the victim for emergency medical ID tags and medications.

**WHEN CALLING FOR
PROFESSIONAL MEDICAL HELP
REMEMBER**

First: Give the location. It is a good idea to mention something readily noticeable that will help them spot the scene.

Then: If feasible, give information about what happened, the number of injured persons, first aid given, and additional equipment needed.

**WHAT TO DO UNTIL HELP ARRIVES:
WHEN THEY HAVE STOPPED BREATHING**

DETERMINE RESPONSIVENESS

- If the victim appears unconscious, gently shake a shoulder and shout: "Are you okay?"
- If no answer, have someone call Emergency Medical Service (usually 911) and proceed to ABC's. If alone with an adult victim, call EMS before proceeding with ABC's.

**CONTACT WITH OR HANDLING OF BLOOD OR BODY FLUIDS MAY BE
HAZARDOUS TO YOUR HEALTH. WEAR GLOVES; USE BARRIERS!**

AIRWAY

- Roll the victim onto his or her back. Move the entire body as one unit.
- Open the airway by the head-tilt/chin-lift maneuver.
- Look, listen and feel for breathing for 3-5 seconds.
- If none, continue.

BREATHING, GIVE 2 FULL BREATHS

- Pinch the victim's nose. Put your mouth over the victim's mouth and make a good seal.
- Give 2 full breaths.
- Allow the victim's lungs to deflate between breaths.

CIRCULATION. CHECK PULSE AND BREATHING

- Check the carotid pulse for 5 to 10 seconds.
- If there is a pulse but no breathing, give 1 breath every 5-6 seconds until the victim revives.
- If no pulse, begin CPR only if trained.

CHOKING

ADMINISTER THE HEIMLICH MANEUVER:

1. Ask: "ARE YOU CHOKING?" (Inability to breath, cough, or speak indicates that the answer is probably yes.)
2. PERFORM THE HEIMLICH MANEUVER:
 - Stand behind the victim.
 - Wrap your arms around the victim's waist and grab the fist of one hand with your other hand.
 - Place the thumb side of your fist against the victim's stomach slightly above the navel and below the rib cage.
 - Thrust your fist into the victim's abdomen with up to 5 quick, upward motions. If unsuccessful, reassess victim and technique and repeat thrusts until effective.

BLEEDING

Contact with or handling of blood or body fluids may be hazardous to your health. Wear gloves; use barriers.

- Use direct pressure - apply pressure bandage.
- Maintain direct pressure - add another dressing if blood soaks through. Pressure points may be needed.

BURNS

- Burst blisters of second-degree burns could lead to severe conditions.
- Do not attempt to remove clothes attached to the skin.
- Cool the burnt area with cold water if there are no blisters or the skin is not broken.
- Keep victim lying flat and lightly covered.

POISONING

- Try to determine what was swallowed if victim is conscious.
- Call the Regional Poison Control Center and report the incident. Mention what and how much was taken (if known), the victim's condition and the name and location of the nearest hospital.

CHEST PAIN

- Help victim (if conscious) into comfortable position with the head raised. Loosen tight clothing.
- Help victim take prescribed medication if necessary.
- Activate Emergency Medical Service.
- Begin rescue breathing / CPR if necessary.

CPR

Cardiopulmonary Resuscitation - Perform only if you are trained!

- RESCUER Adult CPR: Perform 30 external chest compressions at 80 to 100 times a minute (30compressions to 2 breaths).
- After one minute, check for carotid pulse.
- If no pulse, resume CPR.
- Check pluse, resume CPR.
- Check pulse every 4 cycles.
- Continue altering chest compressions and rescue breathing until advanced life support is available.

COLD EXPOSURE

Bodies are affected by outside temperatures. Water in our skin tissue can crystallize and freeze, causing abnormal function and sensation. Toes, noses, fingers, and ears are the most comonly affected areas. Frostbite and hypothermia are the two emergencies associated with cold exposure. Hypothermia can be life-threatening and must be treated immediately.

FROSTBITE

Signs and Symptoms

Cold, numb or painful skin that becomes hard and white as pain progresses.

Do Not

- Do not rub affected area.
- Do not break blisters.
- Do not give victim stimulants, including alcohol and tobacco.
- Do not leave victim alone (frostbite can lead to hypothermia, which can lead to death).
- Do not use hot water.

What to do

- Move victim to a warm area.
- Put affected body parts in warm water (100° to 105° F) until skin becomes flushed.
- After warming, keep affected fingers and toes separated with gauze.
- Give warm fluids.
- If normal sensations haven't returned within 30 minutes, seek medical attention.

HYPOTHERMIA

Signs and Symptoms

Mild Hypothermia

- Shivering
- Loss of coordination
- Confusion
- Urge to urinate

Severe Hypothermia

- No longer shivering
- Stumbling
- Irrational behavior
- Slow, irregular heart beat

Do Not

- Do not leave victim alone.
- Do not use hot water to warm victim.
- Do not give hot liquids, alcohol, or anything by mouth.
- Do not allow the victim to move.
- Do not rub or manipulate the extremities.

Your goal is to minimize heat loss and add heat.

What to do

- Monitor the ABC's and get help.
- Remove any wet clothes and submerge victim in warm water (100° to 105° F). Rapid warming is required. If unable to submerge victim, apply warm packs to neck, armits, and groin. If water isn't available, use your own body heat to warm the victim.
- Stay with the victim and keep him or her warm, monitoring the ABC's until help arrives.
- If the victim must be moved, do so gently, keeping the victim in the horizontal position.

HEAT EXPOSURE

The body functions most effectively within a narrow temperature range. High temperatures increase the body's metabolic rate and decrease it's efficiency. Loss of fluid and dialtion of blood vessels occur in an attempt to cool down. The two major medical emergencies associated with heat exposure aer heat exhaustion and heatstroke.

HEAT EXHAUSTION

Signs and Symptoms:

- Sweating: moist, clammy skin
- Nausea, vomiting
- Slightly elevated temperature
- Headache

Do Not

- Do not give victim any stimulant, including alcohol and tobacco.
- Do not apply ice directly to skin.
- Do not allow the victim to become so cold that he or she shivers.
- Do not leave victim alone.

What to do

- Remove victim from heat.
- Apply cool, wet cloths. Fan victim. Stop if victim develops goose bumps or shivers.
- If victim is conscious, give fluids. If possible, have the victim drink a mixture of 1 pint water with 1 teaspoon of salt every 30 minutes until person recovers.
- Seek medical attention if person doesn't continually improve.

HEAT STROKE

Signs and Symptoms:

- Hot, dry skin
- Red or spotted skin
- Extremely high body temperature
- Mental confusion
- Convulsions
- Loss of consciousness

Do not

- Do not give fluids.
- Do not give victim aspirin or any other medication to lower fever.
- Do not give victim any stimulants, including alcohol and tobacco.
- Do not apply ice directly to skin.
- Do not allow victim to become so cold that he or she shivers.
- Do not leave victim alone.

What to do

- Remove person from heat.
- Remove victim's clothing and place him or her in a cool bath; if possible. Or apply cool compresses to body.
- Get medical attention immediately.

HEAT STRESS

The heat stress TLVs specified in table 2 & 3, refer to heat stress conditions under which it is believed that nearly all workers may be repeatedly exposed without adverse health effects. These TLVs are based on the assumption that nearly all acclimatized, fully clothed (e.g. lightweight pants and shirt) workers with adequate water and salt intake should be able to function effectively under the given working conditions without exceeding a deep body temperature of 38°C (100.4° F).

*Where there is a requirement for protection against other harmful substances in the work environment and additional personal protective clothing and equipment must be worn, a correction to the WBGT TLV values, as presented in tables 1, 2 & 3 must be applied. The values in Figure 1 are approximations and are not intended as a substitute for physiological monitoring.

Since measurement of deep body temperature is impractical for monitoring the workers' heat load, the measurement of environmental factors is required which most nearly correlates with deep body temperature and other physiological responses to heat. At the present time, the Wet Bulb Globe Temperature Index (WBGT) is the simplest and most suitable technique to measure the environmental factors. WBGT values are calculated by the following equations:

TABLE 1
EXAMPLES OF PERMISSIBLE HEAT EXPOSURE THRESHOLD
LIMIT VALUES {VALUES ARE GIVEN IN °C AND (F) WBGT}*

| Work-Rest Regimen | Work Load | | |
|-----------------------------------|-----------|-----------|-----------|
| | Light | Moderate | Heavy |
| Continuous work | 30.0 (86) | 26.7 (80) | 25.0 (77) |
| 75% Work - 25% Rest, each hour | 30.6 (87) | 28.0 (82) | 25.9 (78) |
| 50% Work - 50% Rest, each hour | 31.4 (89) | 29.4 (85) | 27.9 (82) |
| 25% Work - 75% Rest, each hour | 32.2 (90) | 31.1 (88) | 30.0 (86) |

For unacclimatized workers, the permissible heat exposure TLV should be reduced by 2.5° C.

TABLE 2

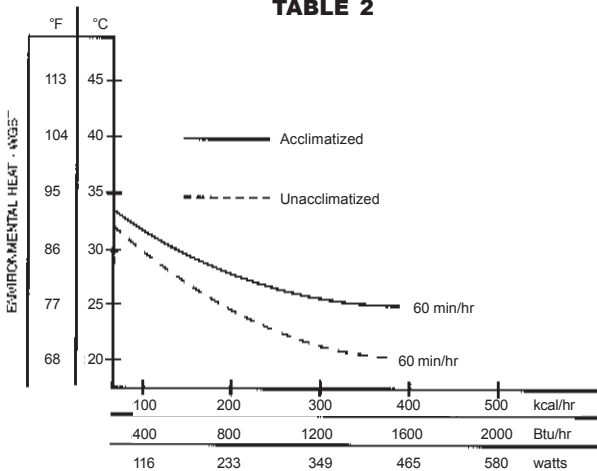

METABOLIC HEAT

*Figure 1 – Permissible heat exposure Threshold Limit Values for heat acclimatized and unacclimatized workers.

TABLE 3

| Index of Heat Stress (H.S.I.) | Physiological and Hygiene Implications of 8 hr. Exposures to Various Heat Stress |
|-------------------------------|--|
| -20 | Mild cold strain. This condition frequently exists in areas where men recover from exposure to heat. |
| -10 | |
| +0 | No thermal strain. |
| +10 | Mild to moderate heat strain. Where a job involves higher intellectual functions, dexterity, or alertness, subtle to substantial decrements in performance may be expected. In performance of heavy physical work, little decrements expected unless ability of individuals to perform such work under no thermal stress is marginal. |
| +20 | |
| +30 | |
| +40 | Sever heat strain, involving a threat to health unless men are physically fit. Break-in period required for men not previously acclimatized. Some decrement in performance of physical work is to be expected. Medical selection of personnel desirable because these conditions are unsuitable for those with cardiovascular or respiratory impairment or with chronic dermatitis. These working conditions are also unsuitable for activities requiring sustained mental effort. |
| +50 | |
| +60 | |
| +70 | Very severe heat strain. Only a small percentage of the population may be expected to qualify for this work. Personnel should be selected (a) by medical examination, and (b) by trial on the job (after acclimatization). Special measures are needed to assure adequate water and salt intake. Amelioration of working conditions by any feasible means is highly desirable, and may be expected to decrease the health hazard while increasing efficiency on the job. Slight "Indisposition" which in most jobs would be insufficient to affect performance may render workers unfit for this exposure. |
| +80 | |
| +90 | |
| +100 | The maximum strain tolerated dialy by fit, acclimatized young men. |

WINDCHILL INDEX

| Wind Speed in MPH | ACTUAL THERMOMETER READING (F) | | | | | | | | | | |
|--|---|----|----|-----|---|-----|-----|-----|---------------------|------|--|
| | 50 | 40 | 30 | 20 | 10 | 0 | -10 | -20 | -30 | -40 | |
| Calm | 50 | 40 | 30 | 20 | 10 | 0 | -10 | -20 | -30 | -40 | |
| 5 | 48 | 37 | 27 | 16 | - | -5 | -15 | -26 | -36 | -47 | |
| 10 | 40 | 28 | 16 | 4 | -9 | -21 | -33 | -46 | -58 | -70 | |
| 15 | 36 | 22 | 9 | -5 | -18 | -36 | -45 | -58 | -72 | -85 | |
| 20 | 32 | 18 | 4 | -10 | -25 | -39 | -53 | -67 | -82 | -96 | |
| 25 | 30 | 16 | 0 | -15 | -29 | -44 | -59 | -74 | -88 | -104 | |
| 30 | 28 | 13 | -2 | -18 | -33 | -48 | -63 | -79 | -94 | -109 | |
| 35 | 27 | 11 | -4 | -20 | -35 | -49 | -67 | -82 | -98 | -113 | |
| 40 | 26 | 10 | -6 | -21 | -37 | -53 | -69 | -85 | -100 | -116 | |
| Over 40 MPH (Little added effect) | LITTLE DANGER (For properly clothed person) | | | | INCREASING DANGER (Danger from freezing of exposed flesh) | | | | GREAT DANGER | | |

The human body senses "cold" as a result of both the air temperature and the wind velocity. Cooling of exposed flesh increases rapidly as the wind velocity goes up. Frostbite can occur at relatively mild temperatures if wind penetrates the body insulation. For example, when the actual air temperature of the wind is 40° F (4.4° C) and its velocity is 30 mph (48km/h), the exposed skin would perceive this situation as an equivalent still air temperature of 13° F (-11° C).

APPENDIX L

SCAFFOLDING - GENERAL REQUIREMENTS

The maximum permissible spans for 2" x 10" or wider planks shall be as shown in the following:

| | Full thickness undressed | | | Nominal thickness | |
|------------------------------------|-----------------------------|----|----|----------------------|----|
| Working Load (lb/ft ²) | 25 | 50 | 75 | 25 | 50 |
| Permissible Span | 10 | 8 | 6 | 8 | 6 |

METAL BRACKETS SCAFFOLDS (WALER JACK)

Brackets shall not be on walers held by wire ties unless there are at least three ties fairly close to each jack. Bolted walers are preferred where brackets are used.

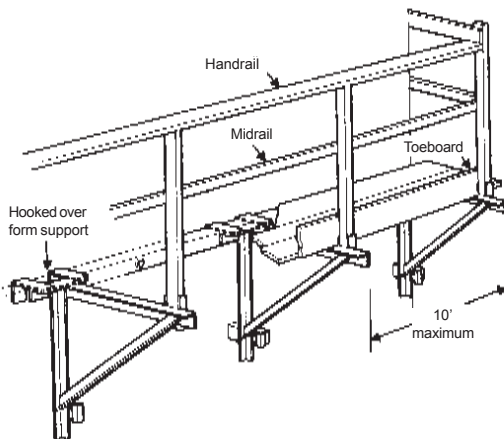

SET METAL SCAFFOLDING

Tie securely to building with #12 double-wrapped wire or some other means with a safety factor of 5.

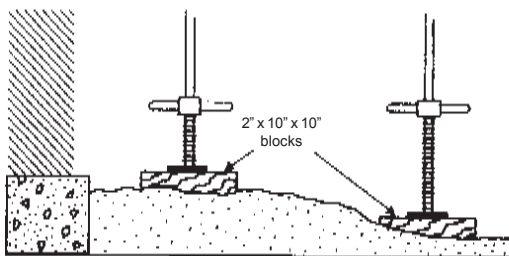
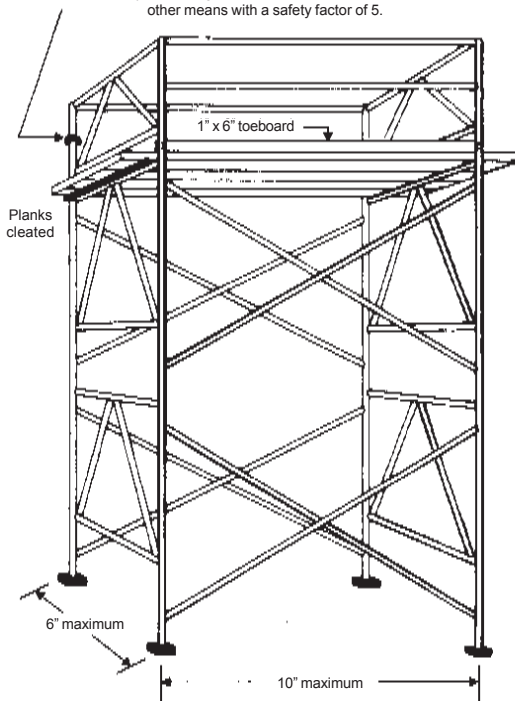

ROLLING METAL SCAFFOLDS

Rolling Scaffolds, when securely tied or guyed, shall be at least one-third as wide at the bottom as they are high.

Screw jacks shall extend into scaffold legs for at least one-third of their length, in no case shall more than 12 inches of the thread be exposed.

The uprights (legs of rolling scaffolds) shall not exceed 24 inches without being braced according to manufacturer's specifications.

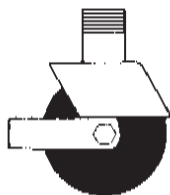
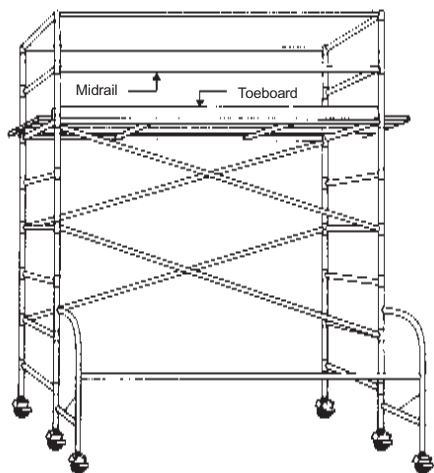

Caster Locked



Caster Unlocked

APPENDIX M

EXCAVATION STANDARDS

B - 1.3 Excavations Made in Type B Soil

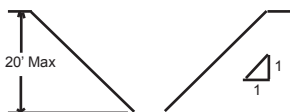

Simple Slope

1. All simple slope excavations 20 feet or less in depth shall have a maximum allowable slope of 1:1.

This bench allowed in cohesive soil only

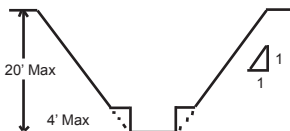

Single Bench

2. All benched excavations 20 feet or less in depth shall have a maximum allowable slope of 1:1 and maximum bench dimensions as shown above.

This bench allowed in cohesive soil only



Multiple Bench

3. All excavations 20 feet or less in depth which have vertically sided lower portions shall be shielded or supported to a height at least 18 inches above the top of the vertical side. All such excavations shall have a maximum allowable slope of 1:1.

Support of Shield System

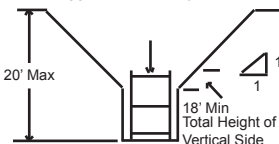

Vertically Sided Lower Portion

4. All other sloped excavations shall be in accordance with the other options permitted in § 1926.622(b).

B - 1.3 Excavations Made in Type C Soil

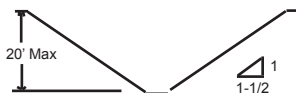

Simple Slope

1. All simple slope excavations 20 feet or less in depth shall have a maximum allowable slope of 1-1/2:1.

Support or Shield System

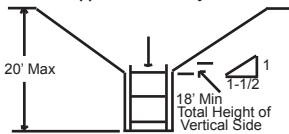

Vertical Side Lower Portion

2. All excavations 20 feet or less in depth which have vertically sided lower portions shall be shielded or supported to a height at least 18 inches above the top of the vertical side. All such excavation shall have a maximum allowable slope 1-1/2:1.
3. All other sloped excavations shall be in accordance with the other options permitted in § 1926.652(b).

MAXIMUM ALLOWABLE SLOPES

| Soil or Rock Type | Maximum Allowable Slopes (h:v) ¹ for Excavations less than 20 Feet Deep 1:3:1 | |
|---------------------------|--|--------------|
| Stable Rock | Vertical | (90°) |
| Type A² | 3/4:1 | (53°) |
| Type B | 1:1 | (45°) |
| Type C | 1-1/2:1 | (34°) |

Notes:

1. Numbers shown in parentheses next to maximum allowable slopes are angles expressed in degrees from the horizontal. Angles have been rounded off.
2. A short term maximum allowable slope of 1/2H 1V (63°) is allowed in excavations in Type A soil that are 12 feet (3.67m) or less in depth. Short-term maximum allowable slopes for excavations greater than 12 feet (3.67m) in depth shall be 3/4H 1V (53°).
3. Sloping or benching for excavations greater than 20 feet deep shall be designed by a registered professional engineer.



Simple Slope - Short Term

Exception: Simple slope excavations which are open 24 hours or less (short term) and which are 12 feet or less in depth shall have a maximum allowable slope of 1/3:1.



Unsupported Vertically Sided Lower Portion - Maximum 8 Feet in Depth

All excavations more than 8 feet but not more than 12 feet in depth with unsupported vertically sided lower portions shall have a maximum allowable slope of 1¹:1 and maximum vertical side of 3-1/2 feet.

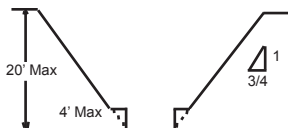

Simple Bench

2. All benched excavations 20 feet or less in depth shall have a maximum allowable slope of 3/4 to 1 and maximum bench dimensions as shown above.

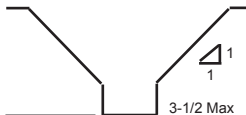

Unsupported Vertically Sided Lower Portion Maximum - 12 Feet in Depth

All excavations 20 feet or less in depth which have vertically sided lower portions that are supported or shielded shall have a maximum allowable slope of 1/4:1. The support or shield system must extend at least 18 inches above the top of the vertical side.



Multiple Bench

3. All excavations 8 feet or less in depth which have unsupported vertically sided lower portions shall have a maximum vertical side of 3-1/2 feet.

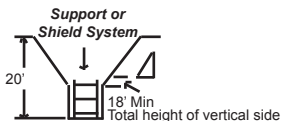

Supported or Shielded Vertically Sided Lower Portion

4. All other simple slope, compound slope, and vertically sided lower portion excavations shall be in accordance with the other options permitted under §

EXCAVATIONS MADE IN LAYERED SOILS

1. All excavations 20 feet or less in depth made in layered soils shall have a maximum allowable slope for each layer as set forth below.

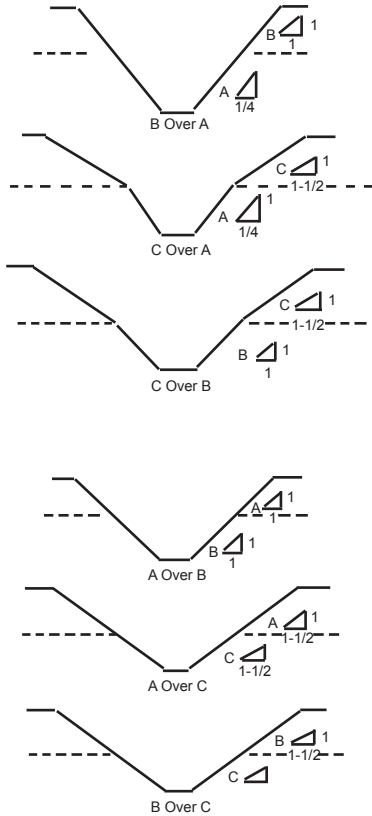

2. All other sloped excavations shall be in accordance with the other options permitted in Section 1926 652(b).

APPENDIX N

DRUG INFORMATION GUIDE

Seven POSSIBLE symptoms of Drug Involvement:

1. Change in work attendance or performance.
2. Alteration of personal appearance.
3. Mood swings or attitude changes.
4. Withdrawal from responsibilities / family.
5. Association with drug using peers.
6. Unusual patterns of behavior.
7. Defensive attitude concerning drugs.

| | Physical Symptom | Look For | Dangers |
|---|---|---|---|
| Alcohol beer, wine, liquor | Intoxication, slurred speech, unsteady walk, relaxation, relaxed inhibitions, impaired | Smell of alcohol on clothes or breath, intoxicated behavior, hang over, slowed reflexes, coordination | Addiction, accidents, overdose, heart & liver damage, glazed eyes |
| Cocaine coke, rock crack, base | Euphoria, elevated blood pressure & heart rate, restlessness, excitement | Glass vials, glass pipes, white powder, razor blades, syringes, needle marks | Addiction, heart attack, seizures, lung damage, severe depression, paranoia |
| Marijuana pot, dope, grass, weed, hash, joint | Altered perception, red eyes, dry mouth, hunger, laughing, euphoria, reduced concentration & coordination | Rolling papers, pipes, dried plant material, odor of burnt hemp, roach clips | Panic reaction, impaired, short term memory, addiction |
| Hallucinogen Acid, LSD, PCP, MDMA, Ecstasy, Mushrooms, peyote | Altered mood, focus on detail, anxiety, nausea, panic | Capsules, tablets, 'microdots', blotter squares | Unpredictable behavior, emotional instability, violent behavior Unconsciousness, |
| Inhalants gas, aerosols, glue, nitrates, Rush, white out | Nausea, dizziness, headaches, lack of coordination and control | Odor of substance on clothing or breath, intoxication, drowsiness, poor muscle control | suffocation, nausea, vomiting, damage to brain and nervous system, sudden death |
| Stimulants Speed, uppers, amphetamines, crank | Alertness, talkativeness, wakefulness, increased blood pressure, loss of appetite, mood elevation | Needle marks on arms, syringes, spoons, pinpoint pupils, cold moist skin | Fatigue, addiction, paranoia, depression, confusion, hallucinations |
| Depressants Barbiturates, Valium, sedatives, alcohol | Barbiturates, Valium, | Capsules, pills, confused behavior. longer periods of sleep, slurred speech | Overdose, muscle rigidity, addiction, withdrawal |

INDEX

| <u>Title</u> | <u>Page #</u> |
|---------------------------------------|---------------|
| Accident Reporting | 36 |
| Air Tools | 14 |
| Alcohol | 6, 38-38, 97 |
| Audio Equipment (See Tape Decks)..... | 26 |
| Boots | 12 |
| Clothing, boots and gloves | 12 |
| Clothing | 12 |
| Combustible Liquids | 24-25 |
| Compressed Gas Cylinders | 14 |
| Concrete Pumps | 15-16 |
| Concrete Shoring | 13 |
| Confined Space Program | 14 |
| Cranes | 15-16 |
| Cutting | 33 |
| Disaster Planning | 19-20 |
| Distribution of Literature | 40 |
| Drugs | 6, 35-39, 97 |
| Drug Policy, LCC | 37-39 |
| Ear Protection | 11, 78-79 |
| Edge Protection | 17 |
| Electrical | 18-20 |
| Emergency Care | 81-90 |
| Employee Responsibilities | 36 |
| Excavations | 18, 94-96 |
| Eye Protection | 10, 41-42 |
| Face Protection | 10, 41-42 |
| Fall Protection | 17-18 |
| Fire Protection | 21, 62 |
| First Aid..... | 25, 80-87 |
| Flammable Liquids | 24-25 |
| Floor Openings | 17 |
| General Safety Guidelines | 13 |
| Gloves | 12 |
| Grinding | 13 |
| Guardrails | 17-18 |
| Hand Signals | 57-59 |
| Hand Tools..... | 26 |

| | |
|--|-----------|
| Hard Hats | 10 |
| Hazard Communication | 22 |
| Heating | 29,33 |
| High Winds (See Disaster Planning) | 16-17 |
| Housekeeping | 23 |
| Injury Reporting | 36 |
| Job Foreman Responsibilities | 35 |
| Ladders | 23, 71-75 |
| Lifting Correctly | 60-61 |
| Lighting | 24 |
| Machinery | 15-16,25 |
| Material Safety Data Sheets | 68-70 |
| Medical Providers | 98-101 |
| Medical Services | 25,98 |
| Metric Conversions | 53-54 |
| Motor Vehicles | 25 |
| Power Tools | 20, 26 |
| Power-Actuated Tools | 26 |
| Protection - General Public | 26 |
| Protection - Noise | 11 |
| Protection - Protruding Reinforced Steel | 29 |
| Protective Equipment | 10-12 |
| Radios - Tape Decks | 26 |
| Respiratory Protection | 11 |
| Riggings | 43-47 |
| Safety Belts | 25 |
| Scaffolding | 27,91-93 |
| Solicitation | 40 |
| Storage Materials | 29 |
| Subcontractor Responsibilities | 7-8 |
| Tape Decks | 26 |
| Temporary Heating | 29 |
| Temporary Help | 9 |
| Theft | 29-30 |
| Toilets | 30 |
| Vandalism | 29-30 |
| Ventilation | 30 |
| Visitors (All) | 9 |
| Wall Openings | 17 |
| Weights & Measures | 51-56 |
| Welding | 33 |
| Workplace Violence | 6, 38 |

NOTES